



EUROPEAN CENTRAL BANK

EUROSYSTEM

# IMPROVEMENTS TO COMMERCIAL BANK MONEY (COBM) SETTLEMENT ARRANGEMENTS FOR COLLATERAL OPERATIONS

JULY 2014

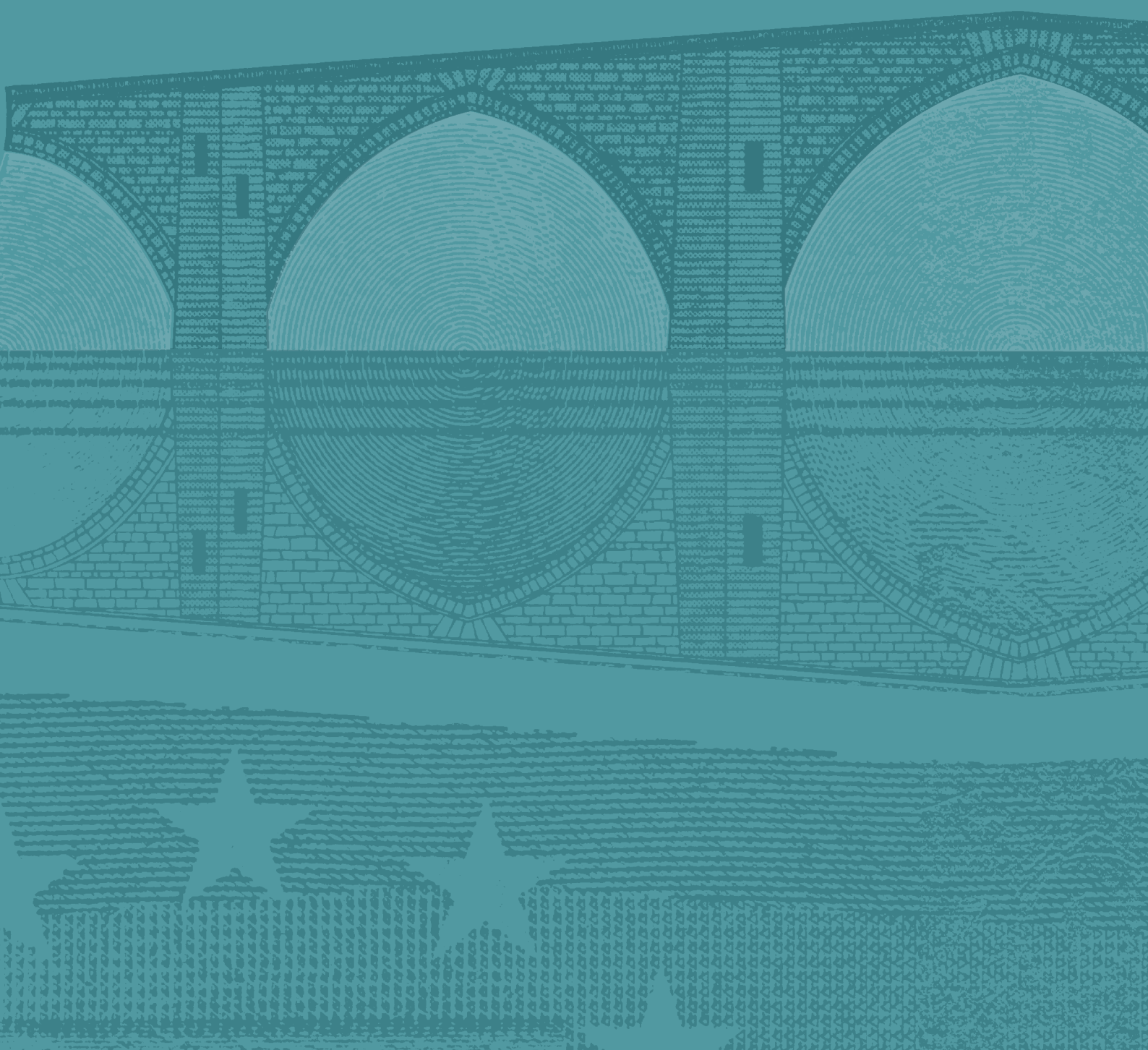



EUROPEAN CENTRAL BANK

EUROSYSTEM



## IMPROVEMENTS TO COMMERCIAL BANK MONEY (COBM) SETTLEMENT ARRANGEMENTS FOR COLLATERAL OPERATIONS

JULY 2014

In 2014 all ECB publications feature a motif taken from the €20 banknote.

© European Central Bank, 2014

**Address**

Kaiserstrasse 29  
60311 Frankfurt am Main  
Germany

**Postal address**

Postfach 16 03 19  
60066 Frankfurt am Main  
Germany

**Telephone**

+49 69 1344 0

**Website**

<http://www.ecb.europa.eu>

**Fax**

+49 69 1344 6000

*All rights reserved. Reproduction for educational and non-commercial purposes is permitted provided that the source is acknowledged.*

ISSN 1831-4147 (online)

ISBN 978-92-899-1370-6 (online)

EU catalogue number QB-04-14-540-EN-N (online)



# CONTENTS

|  |           |
|--|-----------|
| <b>EXECUTIVE SUMMARY</b>   | <b>4</b>  |
| <b>1 SCOPE</b>   | <b>6</b>  |
| <b>2 DESCRIPTION OF COBM PROCESSES AND CUT-OFF TIMES</b>   | <b>8</b>  |
| 2.1 CoBM settlement arrangements   | 8         |
| 2.2 Service deadlines for same-day settlement in CoBM  | 12        |
| 2.3 ERC survey on settlement practices   | 12        |
| 2.4 Description of current business practices  | 18        |
| <b>3 CONSTRAINTS AND DEVELOPMENTS</b>  | <b>20</b> |
| 3.1 Constraints on cut-off times   | 20        |
| 3.2 Constraints and recommendations on trading counterparties' operational processes   | 20        |
| 3.3 Post-trade settlement practices  | 22        |
| 3.4 Developments that could mitigate constraints   | 24        |
| <b>4 RECOMMENDATIONS FOR COBM SETTLEMENT PROCESSES</b>   | <b>27</b> |
| 4.1 Recommendations for enhancements to CoBM settlement processes  | 28        |
| 4.2 Recommendations for (I)CSDs and CSD Links  | 29        |
| <b>ANNEXES</b>   |           |
| 1 Abridged version of ERC Survey: A survey of internal cut-off times for same-day securities settlement instructions   | 30        |
| 2 Abridged version of ERC Survey: The impact of ATS and CCP cut-off times on settlement in commercial bank money   | 37        |
| 3 Glossary   | 38        |
| <b>BOXES</b>   |           |
| Box 1 Illustration of CoBM and CEBM settlement arrangements  | 9         |
| Box 2 Different COBM settlement processing chains  | 10        |
| Box 3 Involvement of intermediaries (Impact on the trading counterparty's cut-off times for same-day COBM settlement in four euro area fixed income markets with DVP settlement) | 14        |
| Box 4 Involvement of ICSDs and Bridge (cut-offs for COBM settlement in four euro area fixed income markets for DVP settlement)   | 16        |
| Box 5 ATS/CCP cut-off times  | 17        |

## EXECUTIVE SUMMARY

Market participants are increasingly reliant on collateral for secured funding and treasury management operations. The increased use of (cross-border) collateral, however, requires the efficient mobilisation of assets across one or more securities settlement systems (SSSs) throughout the day. Currently, market participants often experience limitations on the effective management of their positions and liquidity when trying to “square/ balance positions” by the end of the day.

The objective of this report<sup>1</sup> is to explore current settlement practices in commercial bank money (CoBM) and propose recommendations to support “better use of collateral”, in particular to remove structural constraints and inefficiencies in the settlement of collateral operations in CoBM. In doing so, the report focuses on trades with same-day (T+0) settlement of securities, which is required for the daily management of liquidity, resources (cash/securities) and collateral.

## FACT FINDING

The starting point of the analysis is the operating times and service deadlines for same-day trading and settlement in the European repo market. Currently, timeframes are typically limited when involving different cross-border and cross-system arrangements. This report analyses whether extended operating hours in CoBM could be offered, in view of improvements in central bank money (CeBM) with the launch of TARGET2-Securities (T2S) in mid-2015.

(I)CSDs play a key role in settlement arrangements as the central market infrastructure for securities settlement activities. The report analyses the different cut-off times and processes required by trading counterparties and intermediaries in forwarding instructions to (international) central securities depositories - (I)CSDs, in the context of promoting efficient arrangements for settlement in CoBM. Using data collected from an European Repo Council (ERC) survey on market cut-off times, a comparison is made of the processes involved in sending instructions to an (I)CSD with the possible involvement of several types of intermediaries, creating settlement “chains”. In addition, the report describes processes involving the settlement of instructions originated by automated trading systems (ATs) and central counterparties (CCPs), whereby ATs or CCPs instruct the settlement on behalf of the trading counterparties. These processes (involving the different actors) are referred to in general as “CoBM settlement arrangements” (but it is noted that the ultimate “CoBM settlement” is performed in the SSSs operated by the ICSDs and to a limited extent also by some CSDs).

## ANALYSIS OF CONSTRAINTS

Building on this analysis of CoBM processes and cut-off times, a number of constraints were identified related to the trading counterparties’ operational processes alongside issues related to post-trade settlement practices. Constraints that impact on operational processes include issues related to data collection for the accurate forecasting of funding requirements by trading counterparties, interruptions to straight-through processing (STP) processes caused by internal systems and manual processing and the failure of trading counterparties to harmonise their internal systems deadlines with market deadline extensions. Post-trade settlement practices also generate constraints. These constraints may derive from limitations in infrastructure functionalities, and from specific practices and activities of intermediaries in settlement processing “chains”; such practices and activities

<sup>1</sup> The report has been prepared by a joint group of European Repo Council (ERC) and European Banking Federation (EBF) members, supported by the ECB’s COGESI, on enhancements to settlement of securities transactions in commercial bank money.

may result in earlier intermediary deadlines for same-day settlement. These activities include trade matching requirements, allegation processing, message formatting checks, provisioning and reconciliation of cash and securities, credit risk assessments, management of (I)CSD matching and settlement functionalities, management of failed trades and anti-money laundering requirements. Penalty regimes for failed trades in some specific markets are also identified as contributing factors towards the fixing of earlier intermediary deadlines. There are also constraints that derive from the early cut-off times for same-day settlement across the ICSDs' Bridge or from the non-alignment of operating hours in the case of cross-(I)CSD links.

## DEVELOPMENTS AND RECOMMENDATIONS

The report also considers several market developments that could help mitigate these constraints. These developments include T2S and harmonisation ahead of T2S; the upgrade of the interoperable link arrangement between the two ICSDs (Bridge) and work on triparty settlement interoperability; EU regulation on CSDs (CSDR); ESF-ECSDA proposals on pre-settlement date matching processes; and initiatives aimed at reducing settlement fails and improving settlement discipline.

In response to the issues and constraints identified in the analysis of current CoBM settlement practices, a set of recommendations are presented with the aim of improving same-day delivery versus payment (DVP) settlement-related processes in CoBM.

- Instructing parties are recommended to ensure that all instructions to intermediaries are complete and correct, and transmitted as early as possible. Improvements to the instructing parties' internal systems and bilateral communications with their counterparties are also strongly recommended.
- Intermediaries are recommended to submit their customers' instructions to the relevant SSS (or to the next intermediary in the settlement processing chain) within 30 minutes of receipt. Intermediaries that are direct CSD participants should also ensure they have full capability for submission of customer instructions to the SSS up to the market cut-off (settlement deadline) of the relevant SSS. Short turnaround times are also important for integrated repo markets, particularly end-of-day treasury management transactions, so intermediaries should support a turnaround time<sup>2</sup> of no more than 60 minutes.
- Appropriate systems should be established throughout the settlement processing chain to enable the monitoring of the status of instructions from the next party in the settlement processing chain. Intermediaries and (I)CSDs should aim to promptly inform their respective customers of potential settlement issues (and settlement fails) within 15 minutes of discovery.
- Finally, (I)CSD links in CoBM should support efficient settlement with a view to supporting the use of links for intraday (re)use of collateral, adjustment operations at the end of the day, and central bank operations.

These recommendations should be understood as "guidelines" for the instructing parties, intermediaries and (I)CSDs. In particular, the recommendations offer a set of elements for further alignment of CoBM-related processes that meet the aspirations for improving the efficiency of treasury management-related activities. The recommendations of this report will contribute to the

<sup>2</sup> Turnaround times indicate the interval between receipt of the customer's instruction and delivery of the settlement confirmation, or other relevant updates to the transaction status.



work of the ECB Contact Group on Euro Securities Infrastructures (COGESI) on infrastructure-related improvements to the repo market, which covers enhancements to cross-border settlement arrangements and collateral management mechanisms.

## STRUCTURE OF REPORT

The report is structured as follows: Chapter 1 clarifies the scope, i.e. actors and arrangements for settlement in CoBM. Chapter 2 provides a stock take of current CoBM-related cut-off times and settlement processes. Chapter 3 identifies the main constraints in CoBM settlement arrangements and lists current ongoing developments to reduce these constraints. Chapter 4 suggests recommendations for improving CoBM-related settlement processes. Annex 1 summarises the ERC survey results and Annex 2 provides a glossary.

## I SCOPE

The European repo market is evolving towards more transactions with same-day settlement. One of the main drivers for same-day settlement is treasury management, which increasingly relies on DVP processes. The increased use of CCP clearing and related fulfilment of margin requirements also requires efficient same-day procedures. The windows for same-day trading and settlement in the European repo market are typically limited, although some market infrastructures have started to offer extended operating hours in response to market demand (e.g. Eurex's Euro GC Pooling Market). This report analyses whether extended operating hours could also be offered for other arrangements involving different cross-border and cross-system arrangements.

It is noted that the majority/bulk of the repo market typically settles overnight (with the largest volume and value settled during the night-time settlement window<sup>3</sup>), while same-day (intraday) settlement represents only a smaller part of the market. Most of the settlement in daylight cycles is to handle operations which did not settle in the overnight cycle, and operations related to treasury adjustments executed for same-day value. Overnight settlement is not the focus of this report.

Various actors are involved in CoBM-related arrangements, each with their own different processes and often with different cut-off times. This report uses mainly the following terminology:

- **Trading counterparties:** These are the principals or agents that initiate/originate settlement instructions (e.g. repo participants and traders, also referred to as “repo desks”, and sometimes also the “treasury desks” involved in liquidity adjustment operations). In this report, the term “trading counterparties” refers to all financial institutions that engage in trading activities (e.g. repo counterparties) and are either a direct member of an (I)CSD or an indirect member (using intermediaries/custodians).
- **Intermediaries/custodians:** These hold and administer securities on behalf of their customers and provide a range of information and banking services<sup>4</sup>. This report focuses on how intermediaries process client settlement instructions on behalf of clients (in this respect they are settlement intermediaries), without being a party to the trade (e.g. to forward instructions

<sup>3</sup> Some SSSs operate (gross or net) batch-processing cycles overnight as well as during daytime opening hours. The countries with night-time processes are Germany, France, the Netherlands, Spain and Italy. (T2S will have night-time settlement).

<sup>4</sup> See “The securities custody industry”, ECB occasional paper nr 68, August 2007, by Diana Chan, Florence Fontan, Simonetta Rosati and Daniela Russo.

of customers to SSSs and to reconcile/realign accounts in the settlement processing chain after settlement has occurred). Services of cash correspondents are not covered in the report.

- **(I)CSDs:** These provide custodial services to direct members, but also settle instructions and operate securities settlement systems (SSS). A distinction is made between ICSDs (where settlement is effected in CoBM)<sup>5</sup>, and CSDs (where settlement is effected in CeBM in the vast majority of cases).

The roles and interrelations of the various actors in securities settlement are illustrated in Chart 1.

The starting point of the analysis in this report is the activities of the (I)CSDs in their role as central market infrastructure for securities settlement. The report then analyses the role/processes of trading counterparties and intermediaries<sup>6</sup> in forwarding instructions to the (I)CSD, in the context of promoting efficient arrangements for settlement in CoBM. In particular, a comparison is made of the processes involved in sending instructions to an ICSD against the processes for instructing a CSD. In addition, the report also describes role/processes involving the settlement of instructions originated by automated trading systems (ATS) and central counterparties (CCPs). In this case, ATSS or CCPs instruct the settlement (on behalf of the trading counterparties)<sup>7</sup>. All these processes (involving the different actors) are referred to in general as “CoBM settlement arrangements” (but it is noted that the ultimate “CoBM settlement” is performed in the SSSs operated by the ICSDs and to a limited extent also by some CSDs).

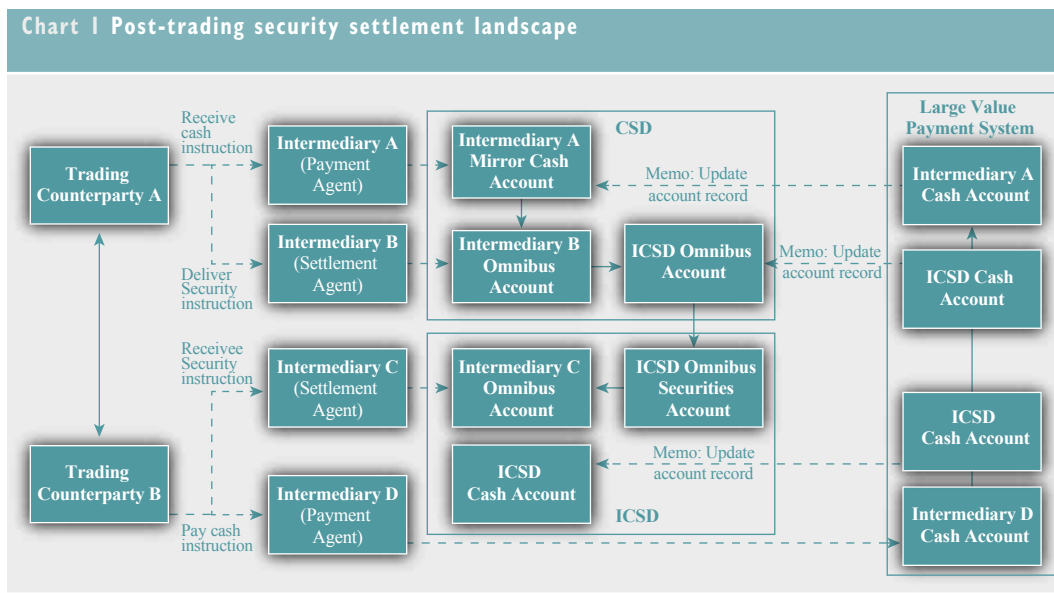

- The report only covers settlement-related services, and does not cover other ICSD services. See “The securities custody industry”, ECB occasional paper nr 68, August 2007. (ICSDs offer combined CSD functions and banking services, by combining book-entry transfer of securities and book-entry payment for those securities via cash accounts held by the ICSD bank).
- This report does not elaborate on the finer details of “internalised settlement”, which refers to the situation where a custodian bank has two customers transacting with each other and the custodian transfers the customers’ securities and cash holdings on its books without having to forward the instructions to the national CSD and payment system. See “The securities custody industry”, ECB occasional paper nr 68, August 2007.
- In particular, either (i) the ATSS forward the instructions of the trading counterparties to the CCP for clearing, and afterwards the CCP instructs the (I)CSD for settlement, or (ii) the ATSS instruct directly the (I)CSD if no CCP is involved.



Although this report focuses on CoBM settlement arrangements in euro, it is recognised that further work examining other currencies (e.g. European Economic Area (EEA) and other main global currencies) could be conducted at a later stage. This future work is particularly relevant considering that CoBM arrangements often involve currencies other than the euro.

This report only focuses on CoBM arrangements (and possible interactions of CoBM with CeBM)<sup>8</sup>. The recommendations of this report will contribute to the work of COGESI on infrastructure-related improvements to the repo market, which covers enhancements to cross-border settlement arrangements and collateral management mechanisms.

## 2 DESCRIPTION OF COBM PROCESSES AND CUT-OFF TIMES

This chapter provides a general description of CoBM settlement arrangements from an operational perspective and outlines the results of a European Repo Council (ERC) fact-finding exercise on cut-off times for settlement in CoBM. The answers to qualitative questions in the fact-finding were also taken into account to complement the information on CoBM settlement practices for fixed-income and, to a lesser extent, equities transactions in selected markets.

### 2.1 COBM SETTLEMENT ARRANGEMENTS

Payments in the wholesale financial markets can be made in CoBM or CeBM. CeBM takes the form of deposits at a central bank and banknotes/coins, while CoBM is money in the form of deposit liabilities of commercial banks (i.e. the settlement asset is provided respectively by the central bank or commercial bank<sup>9</sup>).

There are at least two possible perspectives with respect to the difference between CeBM and CoBM settlement arrangements. One perspective is the perspective of the SSS: an SSS will settle in CeBM or CoBM if at the point of settlement the cash resource that is transferred from the SSS participant receiving the securities to the SSS participant delivering the securities is a claim on a central bank (settlement in CeBM), or a claim on a commercial bank (settlement in CoBM). Another perspective is the perspective of a trading party: if a trading party uses a claim that it has on a commercial bank as a resource to settle a securities transaction, then for that trading party, settlement takes place in CoBM.

The co-existence of CoBM and CeBM settlement arrangements is illustrated in Box 1.

8 The interconnectivity of arrangements in CoBM and CeBM (as explained later in the report) is important for central banks. With the launch of T2S, current differences for CeBM settlement arrangements will be removed for CSDs participating in T2S, i.e. T2S will harmonise operating hours and settlement processes across CSDs in CeBM.

9 For further information on CoBM arrangements, see “The interconnectivity of central and commercial bank money in the clearing and settlement of the European repo market”, ERC, 14 September 2011 and “The role of central bank money in payment systems”, BIS, August 2003. For ICMA, see <http://www.icmagroup.org/assets/documents/Market-Practice/Regulatory-Policy/Repo-Markets/Central%20and%20commercial%20bank%20money%20-%20ICMA%20report%20September%202011.pdf> For BIS, see <https://www.bis.org/publ/cpss55.htm>

Box 1

ILLUSTRATION OF COBM AND CEBM SETTLEMENT ARRANGEMENTS

Illustration of CoBM and CeBM settlement arrangements

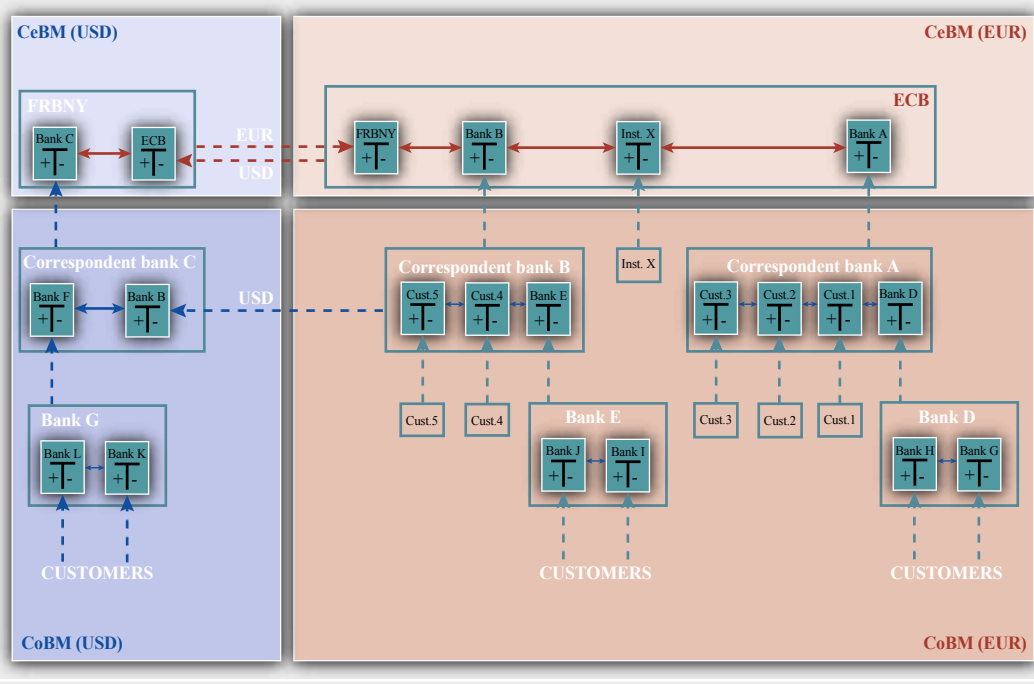

Settlement in CoBM and CeBM is organised according to a given set of procedures, rules, processes and arrangements. This section of the report briefly explains (i) settlement processing types and (ii) settlement processing chains.

**(i) Settlement processing types**

An SSS may settle securities according to different settlement processes, i.e. either with (i) delivery versus payment (DVP) or (ii) free of payment (FOP). Annex 1 provides more detailed information on the different settlement processing types of selected countries.

(i) *DVP* could be either in batch-processing or real-time gross settlement processing.

- *Batch-processing* refers to the transmission/processing of a large number of payment orders and/or securities transfer instructions together with batch-processing “cycles” starting at specified times and implemented on a net basis. If offered, overnight settlement batches typically handle the majority of transactions. Day-time batch-processing cycles are not common and typically have an early cut-off time. This report does not cover batch-processing in detail given its focus on intra-day and same-day settlements.
- *Real-time processing* typically occurs only during the day. There may be different cut-off times for mandatory and optional settlement.

(ii) *FOP* trades involve the transfer of securities from one counterparty to another, without/independently of any related cash transfer. These securities transfers are also a component in financing arrangements, e.g. to realign securities accounts or as part of a substitution of securities or as margin transfers.

- *FOP* settlement can also be either in *batch* or *real-time* processing.

For market participants involved in treasury and funding operations, real-time/DVP settlement processes have become increasingly important. This report, therefore, focuses on real-time DVP settlement.

#### (ii) Settlement processing chains

Settlement instructions can involve several types of intermediaries, creating a “chain” of different actors in the settlement process. Box 2 provides an overview of the different CoBM settlement processing chains. In all these settlement processing chains, settlement takes place in the SSS (operated by the ICSD or CSD). All other actors have to take into account the settlement rules of the (I)CSDs because of the central role of the (I)CSD in the chain. The instructing parties (“CP”) and intermediaries (“custodians”) are bound by the cut-off times and instruction formats of the (I)CSD. Hence, in Box 2, the diagram illustrates that arrows are directed from the trading counterparties that initiate the trades and originate the settlement instructions to the (I)CSDs that operate the SSSs where those settlements are effected.

It is noted that CCPs and ATs can also be involved in CoBM processes, but they are not shown as part of separate settlement processing chains in the overview. CCPs and ATs typically act as the instructing party in the settlement processing chain, so there is no need for a separate settlement processing chain. A separate section in the report is dedicated to CCPs’ and ATs’ cut-off times because of the importance of CCPs and ATs in the repo market.

In addition to the aforementioned actors, the internal processes of the instructing party also play an important role. In some cases, an instructing party could set its own internal cut-offs for its traders at the “repo desk”, and these could be considerably earlier than the cut-offs of the (I)CSD. Even with longer (I)CSD operating hours, the treasury desk could still set earlier cut-offs (referred to as internal deadlines), e.g. for collateral management purposes. Internal processes can also vary depending on the size, volumes and also the level of automation and sophistication of internal operational arrangements. In some cases, larger volumes may need more active collateral and liquidity management at the end of the day, thus requiring earlier internal deadlines of trading counterparties in order to process those transactions.

#### Box 2

##### DIFFERENT COBM SETTLEMENT PROCESSING CHAINS

From an operational perspective, counterparties (CP) can use a number of different settlement processing chains involving CoBM and CeBM. Each of the scenarios depicted below relate to one trade executed between the two trading counterparties at each side, which generates a series of settlement instructions to be processed along different variations of “intermediary chains”, and eventually to be matched and settled in one (I)CSD in the middle of these “chains”.

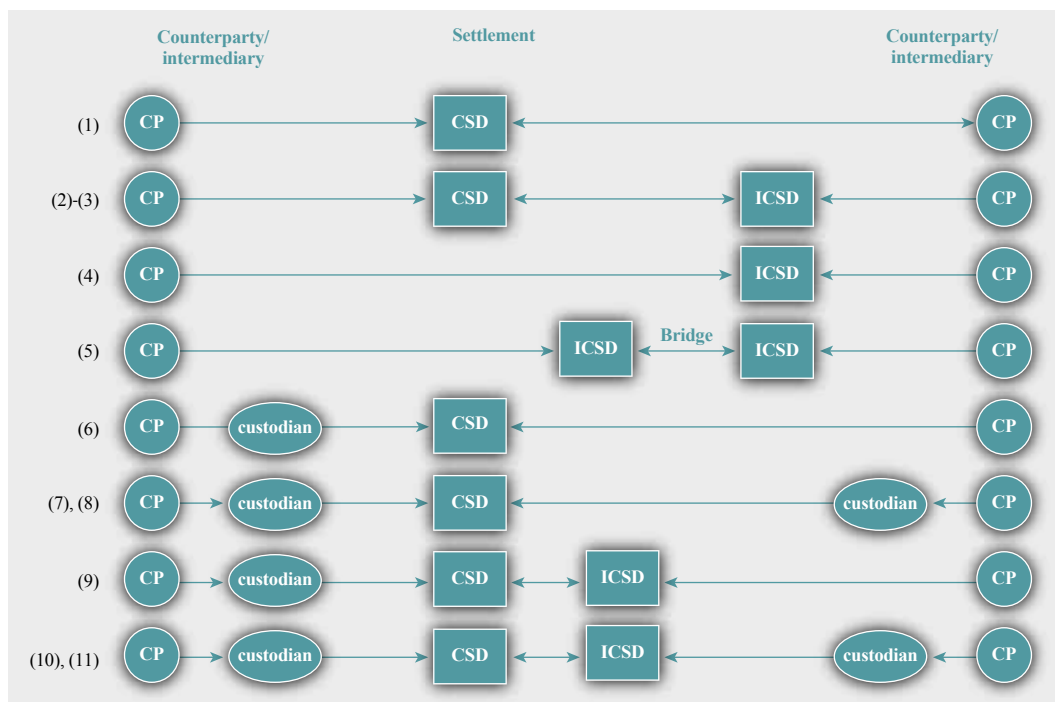

The following scenarios (settlement processing chains) have been identified<sup>1</sup>:

- (1) “Counterparty – CSD – counterparty” (this is settlement in CeBM): both parties are direct members of the CSD with payments occurring in an RTGS;
- (2) “Counterparty – CSD – ICSD – counterparty”<sup>1</sup>: one party is a direct member of the CSD, the other of the ICSD;
- (3) “Counterparty – ICSD – CSD – counterparty”<sup>1</sup>: one party is a direct member of the ICSD, the other of the CSD;
- (4) “Counterparty – ICSD – counterparty”<sup>1</sup>: both parties are direct members of the same ICSD;
- (5) “Counterparty – ICSD – ICSD – counterparty”<sup>1</sup>: the parties are direct members of different ICSDs, which are connected by “The Bridge”;
- (6) “Counterparty – custodian – CSD – counterparty”<sup>1</sup>: one party uses a custodian to connect to the CSD, while the other is a direct member;

<sup>1</sup> In this report, settlement processing chains are shown where the settlement is taking place in the CSD or ICSD. Where multiple (I)CSDs are involved (e.g. scenarios 2, 3, 5, 9, 10 and 11), then settlement occurs in **one** (I)CSD, while the other (I)CSD acts as an “investor CSD” (effectively acting as another custodian or intermediary in the settlement chain). The counterparty (CP) initiates or originates the transaction with an instruction, while the custodian forwards the instruction to the (I)CSD or confirms settlement to the counterparty. It is noted that other variations and combinations could be possible, with increasing complexity.

- (7) “*Counterparty – custodian – CSD – same custodian – counterparty*”: both parties use the same custodian to connect to the same CSD;
- (8) “*Counterparty – custodian – CSD – different custodian – counterparty*”: the parties use different custodians to connect to the same CSD;
- (9) “*Counterparty – custodian – CSD – ICSD – counterparty*”: one party uses a custodian to connect to the CSD, while the other is a direct member of an ICSD;
- (10) “*Counterparty – custodian – CSD – ICSD – same custodian – counterparty*”: one party uses a custodian to connect to the CSD, while the other uses the same custodian to connect to an ICSD);
- (11) “*Counterparty – custodian – CSD – ICSD – different custodian – counterparty*”: one party uses a custodian to connect to the CSD, while the other uses a different custodian to connect to an ICSD).

These chains are stylised and, in practice, can be more complicated, e.g. due to the use of sub-custodians, but the chains shown above illustrate the essential principles.

## 2.2 SERVICE DEADLINES FOR SAME-DAY SETTLEMENT IN COBM

In this report, a comparison is made between the different cut-offs:

- **Initiating deadlines:** The trading counterparties’ internal deadlines to originate a settlement instruction (e.g. internal deadlines for the repo desk or treasury desk).
- **Intermediary deadlines:** The cut-offs of intermediaries/custodians. One key function of intermediaries is to forward instructions, thereby taking responsibility for the onward submission of the settlement instruction originated by a trading counterparty either to the next intermediary in the chain or directly into the settlement system<sup>10</sup>.
- **Settlement deadlines:** The cut-offs of (I)CSDs are “structural” deadlines of market infrastructures, i.e. the latest time for instructions to be settled on a particular settlement day, after which point the submission of an instruction for same-day processing is no longer possible. (I)CSD cut-offs are therefore also referred to as market cut-offs<sup>11</sup>.

## 2.3 ERC SURVEY ON SETTLEMENT PRACTICES

As a starting point of the analysis on CoBM settlement practices, a survey was conducted on initiating deadlines in selected markets among ERC Operations Committee member firms.

<sup>10</sup> Whether the trading counterparty’s instruction meets the intermediary’s deadline or not does not prevent the intermediary from processing the transaction. The significance of the intermediary deadline is related to the “liability” accepted by the intermediary to meet a specific deadline set by an infrastructure. It is noted that (I)CSDs links could also involve intermediary deadlines, i.e. the investor (I)CSD’s deadline to forward the instruction to the (I)CSD of settlement (e.g. Issuer CSD).

<sup>11</sup> It is noted that “settlement deadlines” will be aligned for CSDs that migrate to T2S. In particular, T2S will have a DVP cut-off 4 p.m. CET and until 5.40 p.m. CET for treasury-related DVP transactions (BATM). T2 is open until 6 p.m. CET.

The objective was to identify possible systematic inefficiencies in securities settlement in CoBM on the basis of early or inconsistent cut-off times. It is recognised that an early cut-off is only one dimension of settlement efficiency, albeit a significant dimension. Additional background information was provided by members of the Joint Group on CoBM to complement the findings from the survey.

The survey collected information from 13 major banks active in the repo market<sup>12</sup> on their latest “initiating deadline” for sending instructions for same-day settlement and compared it with the intermediaries and settlement/market deadlines. The survey analysed the various alternative settlement processing chains summarised in Box 2 for fixed-income settlement in the four largest eurozone countries (DE, FR, ES and IT - see Annex 1 for country-specific information).

The following sections provide the findings of the survey on cut-offs involving (i) intermediaries/custodians; (ii) (I)CSD links in CoBM, and (iii) ATs/CCPs.

### 2.3.1 DEADLINES WITH INVOLVEMENT OF INTERMEDIARIES/CUSTODIANS

Intermediaries and custodian banks provide trading counterparties with access to CSDs, along with other processing services. Although the use of intermediaries inevitably adds complexity and results in earlier deadlines along the settlement processing chain, it should be noted that the choice of using intermediaries for settlements processing is driven by numerous other considerations (e.g. benefits relating to the use of a dedicated technical and operational infrastructure operated by the custodian), which often outweigh other drawbacks and delays.

The deadlines involving an intermediary should be seen in relation to the (I)CSDs deadlines for direct participants in (I)CSDs. In particular, intermediary deadlines are dependent on the cut-offs defined by (I)CSDs, and the intermediary deadlines are always set before the (I)CSD deadlines. The survey analysed how much time there was between intermediary deadlines and the (I)CSD deadlines. It must be noted that all services offered by intermediaries are of a commercial nature and as such, the services offered may vary according to those commercial arrangements (e.g. deadlines may be earlier if intermediaries have to put the instructions of their clients in the correct format).

Regarding same-day DVP settlement, the involvement of intermediaries could lead to earlier cut-offs for trading counterparties of up to two hours (in DE, FR and IT) and even up to four hours (in ES, see Box 3) compared with direct participation of a trading counterparties in (I)CSDs.

<sup>12</sup> It is noted that the number of financial institutions involved in the sample is limited, and other scenarios or findings could be reached with larger samples. The survey results are therefore indicative. Nevertheless, the size and importance of the responding financial institutions in the repo market does mean the survey results can be used to provide a good impression of the actual market practices. In addition, any “outliers” (i.e. responses that were very different compared with other responses) were discussed and clarified with the respondents to ensure a common understanding of the questions.



Box 3

**INVOLVEMENT OF INTERMEDIARIES (IMPACT ON THE TRADING COUNTERPARTY'S CUT-OFF TIMES FOR SAME-DAY COBM SETTLEMENT IN FOUR EURO AREA FIXED INCOME MARKETS WITH DVP SETTLEMENT)<sup>1</sup>**

|                   | Settlement processing chain                                 | (I)CSD "settlement deadlines"                            | Trading counterparties' "initiating deadlines" (Trading counterparties' internal cut-off for sending SDS instructions) |  |
|-------------------|---|--|--|--|
|                   |   |  | Earliest – Latest trading counterparties internal cut-off times  | Range between trading counterparties internal & (I)CSD cut-off times |
| Without custodian | (1) CP – CSD – CP   | DE: 4 p.m.<br>FR: 4 p.m.<br>IT: 4.15 p.m.*<br>ES: 4 p.m. | DE: 4 p.m.<br>FR: 3 p.m. – 3.50 p.m.<br>IT: 1.30 p.m. – 4.15 p.m.<br>ES: 3 p.m.  | DE: 0 hr<br>FR: 1hr<br>IT: 2 ¼ hrs<br>ES: 1 hr                       |
|                   | (4) CP – ICSD – CP  | ICSD: 6.30 p.m.**  | DE: 4 p.m. – 6.30 p.m.<br>FR: 4 p.m. – 6.30 p.m.<br>IT: 4 p.m. – 6.30 p.m.<br>ES: 3.30 p.m. – 6.30 p.m.                | DE: 2 ½ hrs<br>FR: 2 ½ hrs<br>IT: 2 ½ hrs<br>ES: 3 hrs               |
| With custodian    | (6) CP – Custodian – CSD – CP                               | DE: 4 p.m.<br>FR: 4 p.m.<br>IT: 4.15 p.m.<br>ES: 4 p.m.  | DE: 1 p.m. – 3 p.m.<br>FR: 3 p.m. – 4 p.m.<br>IT: 2 p.m. – 4.15 p.m.<br>ES: 12 noon – 4 p.m.                           | DE: 3 hrs<br>FR: 1 hr<br>IT: 2 ¼ hrs<br>ES: 4 hrs                    |
|                   | (7) CP – custodian – CSD – same custodian – CP              |  | DE: 1 p.m. – 3 p.m.<br>FR: 3 p.m. – 4 p.m.<br>IT: 2 p.m. – 4.15 p.m.<br>ES: 12 noon – 4 p.m.                           | DE: 3 hrs<br>FR: 1 hr<br>IT: 2 ¼ hrs<br>ES: 4 hrs                    |
|                   | (8) CP – custodian – CSD – different custodian – CP         |  | DE: 1 p.m. – 3 p.m.<br>FR: 3 p.m. – 4 p.m.<br>IT: 2 p.m. – 4.15 p.m.<br>ES: 12 noon – 4 p.m.                           | DE: 3 hrs<br>FR: 1 hr<br>IT: 2 ¼ hrs<br>ES: 4 hrs                    |
|                   | (9) CP – custodian – CSD – ICSD – CP                        | ICSD: 6.30 p.m.  | DE: 1 p.m. – 3 p.m.<br>FR: 3 p.m. – 4 p.m.<br>IT: 2 p.m. – 4.15 p.m.<br>ES: 12 noon – 4 p.m.                           | DE: 3 hrs<br>FR: 1 hr<br>IT: 2 ¼ hrs<br>ES: 4 hrs                    |
|                   | (10) CP – custodian – CSD – ICSD – same custodian – CP      | DE: 4 p.m.<br>FR: 4 p.m.<br>IT: 4.15 p.m.<br>ES: 4 p.m.  | DE: 1 p.m. – 3 p.m.<br>FR: 3 p.m. – 4 p.m.<br>IT: 2 p.m. – 4.15 p.m.<br>ES: 12 noon – 4 p.m.                           | DE: 3 hrs<br>FR: 1 hr<br>IT: 2 ¼ hrs<br>ES: 4 hrs                    |
|                   | (11) CP – custodian – CSD – ICSD – different custodian – CP |  | DE: 1 p.m. – 3 p.m.<br>FR: 3 p.m. – 4 p.m.<br>IT: 2 p.m. – 4.15 p.m.<br>ES: 12 noon – 4 p.m.                           | DE: 3 hrs<br>FR: 1 hr<br>IT: 2 ¼ hrs<br>ES: 4 hrs                    |

\* The Italian market also has a further "reserved window" for settlement between 4.15 p.m. and 6 p.m., whereby trading counterparties can instruct for late settlement by bilateral agreement until 5.50 p.m.  
\*\* Will be extended up to 8 p.m. as at April 2014.

<sup>1</sup> The range of cut-off times has been rounded to the nearest hour for comparative purposes. In addition, the latest possible time for a trading counterparty to initiate an instruction is typically not possible until/at the (I)CSD cut-off time, and instructions should be sent a few minutes earlier than the (I)CSD deadline.

When comparing the direct participation of a trading counterparty in an (I)CSD (scenario 1 and 2) with the trading counterparty's participation via an intermediary to an (I)CSD (scenario 6 to 11), it appears that the internal cut-offs times for transmission of settlement instructions through custodians are earlier than those of direct participation in an (I)CSD for same-day DVP settlement of German and Spanish fixed income securities. In particular, trading counterparties' internal cut-offs could be as early as 12 noon in ES and 1 p.m. in DE when involving a custodian (compared to CSD

settlement deadlines of 4 p.m. in ES; and compared to the mandatory settlement ending at 1.15 p.m. in DE while an optional real-time window is available until 4 p.m. in DE if both parties instruct accordingly). Annex 1 also shows similar findings for FOP settlement and batch-processing.

### 2.3.2 DEADLINES INVOLVING (I)CSD LINKS IN COBM

Settlement in CoBM involving (I)CSD links typically have earlier cut-offs for sending settlement instructions than transactions in a single (I)CSD. These earlier cut-off times for cross-(I)CSD transactions apply to direct participants of (I)CSDs as well as to participation via a custodian. The operating hours of the investor (I)CSD may be dependent on the operating hours of the issuer CSD. The cut-off times and the settlement efficiency for cross-(I)CSD transactions are also influenced by the technical design of the link itself (e.g. batch files or real-time processing) and the legal framework that governs the operation of the link (e.g. settlement finality rules). A distinction can be made between CSD-ICSD links and ‘the Bridge’ (which is the ICSD-ICSD link):

- CSD-ICSD links: The survey results suggest that the existence of links between the CSD and an ICSD does not lead to significantly earlier cut-off times compared to transactions involving a single CSD. In particular, comparing rows 9-11 (i.e. settlement through custodians with a CSD-ICSD link) with rows 6-8 (without CSD-ICSD links), the involvement of a CSD-ICSD link does not introduce any additional delay. This is important, as settlement in European markets is characterised by many CSD-ICSD links because of the preference of many domestic fixed income investors for holding accounts at domestic CSDs and the preference of dealers and global investors for concentrating accounts at ICSDs.
- ICSD-ICSD link (the Bridge): The Bridge operates from 9 p.m. CET (on SD-1) to 6 p.m. CET (on SD), on the basis of 30 exchanges of instruction-matching files, as well as 15 deliveries of settlement instruction files (per ICSD) (i.e. one delivery file every hour per ICSD on average). Bridge cut-off times are as follows:
  - 8 p.m. on SD-1: input deadline for settlement in night-time processing
  - 1 p.m. on SD: input deadline for settlement in mandatory period
  - 3 p.m. on SD: input deadline for DVP settlement in optional period
  - 4 p.m. on SD: input deadline for FOP settlement in optional period

Contrary to CSD-ICSD links, the Bridge cut-offs are not technically dependent on the domestic CSDs’ deadlines (as settlement over the Bridge does not require gross realignment in the local market). Bridge deadlines should be compared to internal ICSD deadlines, i.e. 6.30 p.m. CET today. However, it is also important to look at the interaction/interconnection of the ICSDs with CSDs (to consider the whole market). For example, it would not be useful for a participant to receive Spanish securities from an ICSD participant at a time when they are no longer able to deliver the securities onwards to the local CSD.

**Box 4**
**INVOLVEMENT OF ICSDS AND BRIDGE (CUT-OFFS FOR COBM SETTLEMENT IN FOUR EURO AREA FIXED INCOME MARKETS FOR DVP SETTLEMENT)**

|        | Settlement processing chain | (I)CSD "settlement deadlines"  | Trading counterparties' "initiating deadlines"<br>(Trading counterparties' internal cut-off for sending SDS instructions) |  |
|--------|-----------------------------|--|---|--|
|        |                             |  | Earliest – Latest trading counterparties internal cut-off times   | Range between trading counterparties internal & (I)CSD cut-off times |
| ICSD   | (4) CP – ICSD – CP          | ICSD: 6.30 p.m.  | DE: 4 p.m. – 6.30 p.m.<br>FR: 4 p.m. – 6.30 p.m.<br>IT: 4 p.m. – 6.30 p.m.<br>ES: 3.30 p.m. – 6.30 p.m.                   | DE: 2 ½ hrs<br>FR: 2 ½ hrs<br>IT: 2 ½ hrs<br>ES: 3 hrs               |
|        | (3) CP – ICSD – CSD – CP    | ICSD: 6.30 p.m.<br>DE: 4 p.m.<br>FR: 4 p.m.<br>IT: 4.15 p.m.<br>ES: 4 p.m. | DE: 2 p.m. – 5.30 p.m.<br>FR: 3 p.m. – 5.30 p.m.<br>IT: 3 p.m. – 4 p.m.<br>ES: 3 p.m. – 4 p.m.                            | DE: 2 hrs<br>FR: 1 hr<br>IT: 1 ¼ hr<br>ES: 1 hr                      |
|        | (2) CP – CSD – ICSD – CP    |  | DE: 3 p.m. – 4 p.m.<br>FR: 3 p.m. – 4 p.m.<br>IT: 5.30 p.m.<br>ES: n/a  | DE: 1 hr<br>FR: 1 hr<br>IT: -<br>ES: -                               |
| Bridge | (5) CP – ICSD – ICSD – CP   | Bridge: 3 p.m. <sup>1</sup>  | DE: 2 p.m. – 3 p.m.<br>FR: 2 p.m. – 3 p.m.<br>IT: 2 p.m. – 3 p.m.<br>ES: 2 p.m. – 3 p.m.                                  | DE: 1 hr<br>FR: 1 hr<br>IT: 1 hr<br>ES: 1 hr                         |

1) The 3 p.m. cut-off time represents the optional settlement period. The deadline for the mandatory DVP settlement period is 1 p.m.

**2.3.3 CUT-OFFS WITH AUTOMATIC TRADING SYSTEMS (ATSS) AND CENTRAL COUNTERPARTIES (CCPS)**

A supplementary survey was conducted among ERC members on cut-offs with ATSS and CCPS. The majority of repos in European markets are executed via ATSS and/or cleared through CCPS<sup>13</sup>.

CCP cut-off times can vary greatly depending on the particular ATS and CCP chain used and also the assets to be settled. It is not uncommon for CCP cut-off times to be up to six hours earlier than the CSD cut-off in the same market. The ERC data, as outlined below, show the cut-off times imposed by ATSS for sending instructions with same-day settlement to the respective CSD<sup>14</sup>. The ERC data show the cut-off times of transactions involving the three largest European repo ATS – BrokerTec, Eurex Repo and MTS. The data showed the cut-off times for transactions with ATS and CCPS to be considerably earlier than the cut-off times for OTC and bilateral trading.

- BrokerTec: ATS services are provided in four of the markets examined (DE, FR, IT, ES)<sup>15</sup>, and revealed cut-off times to be quite early in the settlement day. In the German market, it is particularly noteworthy that the ATS cut-off (10 a.m. CET) and the CCP cut off (10.30 a.m. CET) are over five hours before the CSD cut-off (4 p.m. CET).

13 Bilateral repo trades (outside an ATS) can also be cleared at a CCP.

14 It is noted that cross-CSD settlement is also possible (e.g. Clearstream Banking Luxembourg (CBL) and Clearstream Banking Frankfurt (CBF) for settlement of transactions cleared by Eurex Clearing AG (ECAG)).

15 Brokertec also has service for French securities (but only for CCP, not bilateral).

- MTS: Services are provided to all four markets that were examined in the survey. The results were found to be similar to that of BrokerTec, again showing the 10 a.m. CET cut-off for the ATS and 10.30 a.m. CET for the CCP in the German market. The cut-offs for French and Spanish CCP instructions are much later (1.45 p.m. CET), but are still over two hours before the CSD cut-off times (4 p.m. CET).
- Eurex Repo: In the case of Eurex Repo, two segments were considered by the ERC survey, the Euro GC Pooling and the Euro Repo Market.
  - Euro GC Pooling repos can be traded up to 5 p.m. CET (settlement until 5.40 p.m. CET)<sup>16</sup>.
  - For the Euro Repo Market, overnight repo external settlement (settlement between (I)CSDs Clearstream and Euroclear) can be up to 10.30 a.m. CET. The overnight repo internal settlement (within either Clearstream or Euroclear) is up to 3.30 p.m. CET. The survey found a significant difference (five hours) between the cut-off times for centrally cleared repos settling directly at a CSD (3.30 p.m. CET) and those settling across the ICSDs (10.30 a.m. CET).

16 <http://www.eurexrepo.com/repo-en/markets/gc-pooling-market/>

Box 5

ATS/CCP CUT-OFF TIMES

| ATS                                    | (I)CSD<br>"settlement deadlines"                        | ATS/CCP cut-off for sending SDS instructions                    |  |  |
|--|---|---|--|--|
|  |   | ATS cut-off times   | CCP cut-off times  | Range between ATS / CCP<br>& (I)CSD cut-off times            |
| <b>BrokerTec</b>                       | DE: 4 p.m.<br>FR: 4 p.m.<br>IT: 4.15 p.m.<br>ES: 4 p.m. | DE: 10 a.m.<br>FR: 1.15 p.m.<br>IT: 12.45 p.m.<br>ES: 1.15 p.m. | DE: 10.30 a.m.<br>FR: 1.45 p.m.<br>IT: 12.45 p.m.<br>ES: 1.45 p.m. | DE: 6 hrs<br>FR: 2 3/4 hrs<br>IT: 3 1/2 hrs<br>ES: 2 3/4 hrs |
| <b>MTS</b>                             | DE: 4 p.m.<br>FR: 4 p.m.<br>IT: 4.15 p.m.<br>ES: 4 p.m. | DE: 10 a.m.<br>FR: 1.15 p.m.<br>IT: 12.45 p.m.<br>ES: 1.15 p.m. | DE: 10.30 a.m.<br>FR: 1.45 p.m.<br>IT: 12.45 p.m.<br>ES: 1.45 p.m. | DE: 6 hrs<br>FR: 2 3/4 hrs<br>IT: 3 1/2 hrs<br>ES: 2 3/4 hrs |
| <b>Eurex Repo<br/>Euro Repo Market</b> | ICSD DE:  | 6.30 p.m.<br>4 p.m.   | ON ((I)CSD internal): 3.30 p.m.<br>ON (cross (I)CSD): 10.30 a.m.   | DE: 3 hrs cross<br>(I)CSD: 5 1/2 hrs                         |
| <b>Eurex Repo<br/>Euro GC Pooling</b>  | ICSD DE:  | 6.30 p.m.<br>6 p.m.   | EGCP (ON): 5 p.m.  | DE: -<br>FR: : 1hr   |

Note: For Italian market, BrokerTec and MTS accept trade until 12.45 p.m. for specific assets, while GC instructions are processed until 12.15 p.m.

The overnight repos of ATSS/CCPs settle same-day. The early cut-off times of most ATSS/CCPs for same-day settlement would appear to reflect asynchronous batch processes. However, it is likely that later cut-offs would encourage later business (e.g. Eurex's EGCP extended its cut-off times because of market demand).

## 2.4 DESCRIPTION OF CURRENT BUSINESS PRACTICES

This section explains current business practices (i) from the trading counterparty; (ii) intermediary; and (iii) (I)CSD perspective.

### 2.4.1 TRADING COUNTERPARTIES' CURRENT BUSINESS PRACTICES REGARDING CUT-OFFS

In order to maximise the trading day, trading counterparties typically tend to cease trading as close as possible to their own internal funding deadlines. In particular, trading typically stops 15 minutes before the trading counterparty's internal funding deadlines, which are dictated by central bank payment systems (i.e. market deadline). It should also be noted that deadlines vary for different transaction types, i.e. FOP, DVP, batch and real-time settlement.

Treasury management operations often occur throughout the day in order to avoid the accumulation of large funding requirements, which would then have to be satisfied urgently at the end of the day. Treasury management operations can even begin at the start of the day or the previous day, in order to allow large projected balances to be pre-funded. Treasury operations are based on (real-time) projections/forecasts of securities settlement and regular forecasts of intraday and end-of-day cash positions. As the day progresses towards end-of-day, projections and treasury operations are increasingly fine-tuned and adjusted as required, ensuring that trading counterparties do not have to wait until the end-of-day to completely satisfy their funding requirements.

Operations could include internal netting (operational netting of offsetting flows) and pair-offs (operational cancellation of offsetting trades) to reduce the number of instructions and operational costs. This enhances the efficiency of settlement, but most trading counterparties do not see these processes as adding to delays. However, pair-offs could involve telephone or e-mail communication between counterparties and additional processing time has the potential to add delays.

All of these practices have the objective to allow trading counterparties to minimise the volume of CoBM settlements at the end of the day. However, there will still be a need for collateralised end-of-day treasury management operations.

Most trading counterparties do not integrate their repo desk(s) within treasury operations. Independent treasury operations manage unsecured funding. This practice could have the potential for delays and disruptions. However, several trading counterparties are starting to integrate these operations and have a second repo desk within their treasury. On the other hand, those trading counterparties (the majority) that do not integrate repo and treasury stress the close co-ordination between the two areas and do not believe that integration would reduce the time between trading and end-of-day funding. Repo trading has to cease earlier than unsecured funding because CSD cut-off times are earlier than the cut-off times of central bank payment systems.

### 2.4.2 PRACTICES OF INTERMEDIARIES REGARDING CUT-OFFS

Contrary to the definition of a market deadline, which categorically ends the possibility of settlement in the market, a deadline set by an intermediary (**intermediary deadline**) should be understood

as a servicing deadline in the context of bilateral contractual arrangements. Services offered by intermediaries and custodians are of a commercial nature and as such the service levels may differ according to those arrangements. In this context, the servicing deadline denotes the point in time until when intermediaries promise their clients (and agree to take contractual responsibility) that an instruction received within this timeframe and in the agreed format will be submitted for settlement at the local infrastructure by the market cut-off time. Intermediaries define their deadlines on the basis of those imposed on them by (I)CSDs. Hence it should be understood that any intermediary deadline needs to be set prior to the market's deadline.

The receipt of an instruction after an intermediary deadline does not mean automatically that the instruction cannot be processed and settled at the CSD. Intermediaries would still endeavour to transmit and present the instruction for settlement if at all possible. In fact, provided that the formatting requirements of the intermediary and of the local CSD are fully satisfied, "late" instructions received after the contractually agreed intermediary deadlines might also be received and transmitted to the CSD automatically, without active intervention at the level of the intermediary.

Within a client-intermediary relationship, intermediaries generally provide detailed requirements on the structure and content of settlement messages that are exchanged. If all fields are adhered to, an instruction reaching the intermediary, will be validated, and following internally required checks, be forwarded to the market (irrespective of the time).

However, should the instruction content not meet the (I)CSD or the intermediary's requirements, the instruction has to be queued and processed manually, thereby increasing the turnaround time. Intermediaries encourage their clients to send instructions in an STP format.

In order to support trading counterparties and their treasury desks in their planning, intermediaries provide an overview on the forecasted end-of-day cash balances upon request or by agreement also throughout the day.

#### 2.4.3 (I)CSD PRACTICES REGARDING CUT-OFFS

There are no big differences in (I)CSD cut-offs between fixed-income and equities; of the four main European markets (DE, FR, IT and ES), there is only a difference in Spain, which has a different settlement system for equities and for government bonds. However, this market structure will change with T2S and the introduction of common cut-off times for all securities in the Spanish market.

Formats are currently different for each (I)CSD link, but this will also change with T2S with a common formats for participating CSDs/links. For CSD links involving CSDs outside T2S with a connection to CSDs inside T2S (i.e. also referred to as "in – out links"), the differences in formats could remain from a trading counterparty's perspective. Regarding the ICSD-ICSD link (the Bridge), cut-off times differentiate between the "mandatory settlement period" (which is automatically available to all ICSD participants) and the "optional settlement period" (which requires agreement by the ICSD participants), but apply across all currencies and instrument types.



### 3 CONSTRAINTS AND DEVELOPMENTS

This section examines constraints/difficulties when moving to a fully-secured market with same-day (intraday) settlement, (especially for cross-system transactions or through intermediaries).

#### 3.1 CONSTRAINTS ON CUT-OFF TIMES

The ERC survey analysed differences between the time when a trading counterparty sends its instruction and the cut-off of the (I)CSD). In particular, the survey found that the trading counterparty's latest possible time to send instructions differs between different settlement processing chain scenarios (i.e. accessing the (I)CSD's settlement system via intermediaries/custodians, via (I)CSD links, and with the involvement of ATs/CCPs).

- (i) The cut-off times for same-day settlement *across the Bridge* are very early, compared with other cut-off times (i.e. 1 p.m. CET for the “mandatory period”; 3 p.m. CET for DVP “optional period” and 4 p.m. CET for FOP “optional period”).
- (ii) The cut-off times for *links from the ICSDs to CSDs* are early, but these are determined by the CSD operating hours (i.e. CSD operating hours will change with the introduction of T2S).
- (iii) In some markets, the use of intermediaries and *custodian banks (as processing agents)* contributes to earlier cut-off times compared to transactions that do not involve custodians. This is related to the additional systems and processes that intervene in the forwarding of the settlement instructions along the intermediaries chain (note that this does not appear to happen in all markets, which seems to indicate other factors are important as well).
- (iv) The survey also examined the *cut-off times for ATs/CCPs*, on which the vast majority of European repos rely for settlement. These cut-off times are deemed to be more important than the trading counterparties /ATS members' own internal cut-off times and accordingly, any extension of the trading day for the repo market must include the ATs. The bulk of trading is electronic and is constrained by ATs actions.

The responses to the survey also highlighted a significant amount of confusion amongst some trading counterparties regarding cut-off times. This confusion could be confounded by differences in cut-off times published by intermediaries (i.e. earlier than (I)CSDs cut-offs) and the complex range of alternative cut-off times for different types of settlement.

#### 3.2 CONSTRAINTS AND RECOMMENDATIONS ON TRADING COUNTERPARTIES' OPERATIONAL PROCESSES

The following issues were identified within the operations of trading entities, which could lead to delays:

1. **Data Collection:** In order *to correctly forecast funding requirements*, treasury has to have access to accurate data showing cash and inventory positions throughout the day. Delays or inaccuracies in the collection of data on cash balances and inventory is a possible source of delay for treasury management projections. Trading counterparties need adequate systems and processes to collect and collate data from diverse sources, i.e. from custodians/correspondent banks and from (I)CSDs. Trading counterparties may have multiple securities and cash accounts for each of

their main business lines (e.g. broker-dealer, custody and customer clearing), some held with agents and other segmented by legal entity or client, others in omnibus form, as well as core accounts for controlling flows. Systems and processes that can collect and collate data from diverse sources are also required. Data to be collected from correspondent banks, custodians and (I)CSDs include net cash balances for real-time settlement in each market, confirmation that these balances are final, fail notifications and reports on pre-funding already in place. Data are often received by different means (telephone, e-mail and via web portals), which must be collated and assessed, adding to delays. Certain markets are easier to forecast than others because of lower volumes.

The *larger markets require more active forecasting and treasury management* (e.g. DE, FR, IT). The volume of same-day business may encourage earlier internal cut-off times because of the scale of settlement.

The number and size of *failed settlements* are important elements to be considered by market participants when forecasting their funding requirements and necessitate fine-tuning operations as the day progresses (which also leads to costs and penalties). Estimates of expected fails are required as close as possible to the end of the trading day and depend on reported data from (I)CSDs and/or custodians. Particular importance is attached to the reporting requirement in certain markets, perhaps because of the severe penalties imposed on fails and the lack of auto-borrow facilities available. This is reflected in market practices such as telephone pre-matching, which may help explain earlier cut-offs.

2. **Internal systems and manual processing:** These could cause instructions to be incomplete or incorrect, preventing straight-through processing. Internal systems that face internal and external trading counterparties through batch-processing and interface software to interact with SWIFT (and other third party systems) may also contribute to delays. Routine delays may be in the order of 15-30 minutes, but there can be severe and extended disruptions in contingency and recovery scenarios. Manual processes were found to contribute to delays in the settlement process, although generally these delays were found to be not greater than 15 minutes. These manual processes have diverse purposes, but many are a result of failing/failed trades and efforts to rectify those trades (which requires interaction between front office and back office). Manual processes can also include expert judgements, involved in treasury forecasting (and using manual software such as desktop spread sheet applications). Manual intervention is also required in monitoring pre-matching, detecting short positions and advising counterparties, depot realignments, pursuing late or unmatched trades, deal repairs and resends, handling new issues, managing credit lines and securing approvals. However, respondents suggest the usual delays as a result of manual process are not long and are in the order of 15 minutes, although it is not clear how much time they have allowed themselves in setting internal cut-off times in order to anticipate these problems.
3. **Deadline harmonisation:** From a trading counterparty's perspective, there is anecdotal evidence that *internal deadlines of trading counterparties and custodians* have not always been extended *following the extension of market deadlines*. There may also be an element of inertia in the changes of internal operational procedures.

### 3.3 POST-TRADE SETTLEMENT PRACTICES

This section further outlines some of the constraints and requirements, as well as the associated operational processes, which may contribute to delays in the post-trade settlement process. These practices include pre-settlement activities, management of failing trades and procedures to minimise penalties for failed trades.

1. **Matching and affirmation:** The use of post-trade matching services can eliminate many operational errors prior to the commencement of the settlement processes. Whilst this can be very beneficial for trades that are T+3 or for same-day settlement in overnight settlement batches, pre-matching techniques for intraday settlement can prove cumbersome if not automated (quite often dependent on telephone or e-mail communications). In some cases, delayed settlement can occur, particularly in the case of trades instructed late in the settlement day. For such trades, a more productive and efficient solution would be the introduction or enhancement of third-party trade affirmation facilities (for risk management purposes) to service real-time processing that could eliminate the need for telephone/e-mail matching and all associated delays. Also beneficial would be a facility to warn SSS participants of any cash or securities shortages, enabling a prompt response.
2. **Allegements processing and soliciting missing instructions from clients/counterparties:** Missing instructions can cause significant delays and fails in the settlement of same-day trades. Rectifying these missing counterparty instructions can involve several manual procedures and are reliant upon manual intervention. More frequent “allegement” or unmatched reporting (automatic) between custodians/agents and their client trading counterparties could serve to efficiently identify missing counterparty instructions and unmatched alleged instructions, allowing for the prompt correction of errors in advance of settlement deadlines. Whilst most missing instructions can be identified well in advance for trades instructed before settlement date, it is significantly more difficult to do this in a same-day context due to the reduced timeframes.
3. **Performance of formatting checks:** Application of message conversions to make instructions “CSD ready”: Most trading counterparties’ internal systems have been developed to meet their own specific requirements. However, when instructing in the market, these systems often have to translate their internal message formats into one that is compatible with (ISO standard) message formats of (I)CSDs. Depending on the internal system of the trading counterparty, the time to complete this translation can vary, particularly if relying on instruction generation via batches, thus potentially contributing to delays in issuing settlement instructions.
4. **Application of securities and cash provisioning and reconciliation:** The forecasting and provisioning of cash and securities as per a trading counterparty’s requirements is dependent on accurate and up-to-date data being received from intermediaries/custodians, agents and CSDs detailing settled and failed trades and potential cash and stock shortfalls. Internal reconciliation systems can fail to keep pace with settlement information leading to further inefficiencies. The consequence of data not being current can create further problems, e.g. trades being booked when there is insufficient stock or cash available, which will create further fails and delays. Systems could also be unable to cater for more frequent reporting from (I)CSDs.

5. **Performance of credit risk assessments:** In addition to position control on cash and securities, intermediaries/custodians are also frequently required to perform a series of credit risk verifications against their respective clients. In fact, as part of the additional value-added services that they offer to clients, settlement agents often provide intraday credit facilities to support their clients' securities settlements, thus minimising the need for pre-funding or intraday funding by the trading counterparties. In this case, the intermediary/custodian provides its own cash resources into the settlement system to facilitate the securities settlements of its trading clients, up to a predefined limit which corresponds to the credit line established against each client. The daily net total of cash resources provided by the intermediary is refunded at the end of day by the trading counterparty. Monitoring the utilisation of these credit lines on a real-time basis is therefore an additional step in the activities of the intermediary before settlements can be completed. Efficient credit monitoring also implies sufficient flexibility to promptly react to any negative events affecting the creditworthiness of each client, as well as to any unexpected excess usage beyond the predefined limit, possibly leading to the need for urgent excess credit approvals or to the blocking of further settlements until additional funding can be obtained (e.g. waiting for other delivery settlements to be executed which would generate cash against the cash account of this client or ad-hoc funding from the client directly).
6. **(I)CSD functionalities related to matching and settlement:** (I)CSD functionalities have a significant impact on the way intermediaries interact with the settlement system. These range from their local borrowing and lending processes to inventory recall and prioritisation of deliveries. In particular, a lack of a full hold/release mechanism may cause intermediaries to delay transmission of settlement instructions to the SSS, or may cause intermediaries to put in place manual processes to cancel instructions in order to free resources to allow other transactions to settle. Similarly, limitations in the settlement optimisation services offered by an (I)CSD (such as partial settlement, linkage of transactions, and "circles" settlement, etc.) may mean that intermediaries effect manual "exception" processing in order to increase settlement rates, or to solve problems.
7. **Infrequent and asynchronous batches:** Different interconnected processes, especially for cross-CSD and Bridge transactions (linked settlement processing chain), lead to complexities/inefficiencies. The technical design of the (I)CSD link can certainly influence the efficiency of cross-border settlement as a batch-based link may offer fewer opportunities for counterparties to settle and realign their securities. As an illustration, the settlement of a transaction over the Bridge takes about 60 minutes on average, whereas the same transaction within a single ICSD would settle on a quasi-real-time basis. Likewise, the differences of deadlines in cross-(I)CSD settlement is another obstacle to efficient cross-border settlement. The use of different formats, could also create complications/complexity. Settlement processes that do not run synchronised, or need other processing due to different legal requirements) /formats (messaging format, field contents might differ). Complexity could be reduced if CoBM processes were better integrated.
8. **Settlement fails disincentives:** As a disincentive to settlement fails, some markets have in place a penalty regime to cater for failed trades, which are implemented to varying degrees. For example, in one EU market, members of the CSD are actually prohibited from failing to deliver, thus ensuring that the number of fails is kept to a minimum. However, members of the local CSD are often reluctant to trade with non-members (who can have failed trades), as this would expose them to the delivery failures with other counterparties and potential punitive

action, thus increasing their own costs, which could have the effect of isolating the domestic market in government securities.<sup>17</sup> Anecdotal evidence suggests that trading counterparties may be unwilling to mobilise assets out of the local CSD for fear of future failed deliveries of securities and potential punitive action. Instead, they have taken steps whereby securities are borrowed – “doubling up” on positions - in order to cover any failed deliveries and avoid the associated penalties rather than rely on incoming securities. In many cases, trading counterparties are left with overnight positions at the CSD, which often remain unutilised. The disincentive from the penalties for failed settlements has had the knock-on effect of hampering the effectiveness of settlement in this market.

9. ***Constraints arising from government sanction lists/anti-money laundering requirements:*** Regulatory/legal obligations may be placed on intermediaries to perform additional checks on instructions. One example of such checks is the scanning of instructions to detect key words or names that may trigger investigations as to whether parties to a transaction appear on sanction lists, or are associated with money laundering or financing of terrorism. As such scanning of instructions may generate “false positives”, all instructions that do not automatically pass the scanning require individual analysis and investigation, possibly resulting in some additional delays in their onward processing.

### 3.4 DEVELOPMENTS THAT COULD MITIGATE CONSTRAINTS

A number of initiatives/developments are currently in progress that could contribute in mitigating some of the constraints mentioned in the previous section, i.e. (i) T2S and harmonisation ahead of T2S, (ii) upgrade of the Bridge and work on triparty settlement interoperability, (iii) the proposed EU regulation on CSDs (CSDR<sup>18</sup>), (iv) ESF-ECSDA proposals on pre-settlement date matching processes, (v) work on reducing settlement fails and improving settlement discipline.

#### **(i) T2S and harmonisation ahead of T2S**

In today’s market, CSDs operate in a non-standardised manner with varying cut-off times, which are often relatively early in the settlement day. The introduction of T2S will bring harmonised and extended operating times as well as standardised messaging, addressing many of the existing deficiencies. T2S will provide a central pan-European settlement platform, which will optimise settlement of repo transactions by offering real-time settlement in CeBM on a delivery versus payment (DvP) basis. The T2S operating day will consist of several windows for settlement (and a later cut-off for end-of-day treasury operations) and common cut-off times: (i) the cut-off for regular DVP transactions is at 4 p.m., (ii) the cut-off for treasury adjustment operations (on a DVP basis) is at 5.40 p.m. T2S will greatly contribute to the efficient functioning of the repo market and will allow for extended cut-off times.

17 See the ICMA-ERC “White paper on the operation of the European repo market, the role of short-selling, the problem of settlement failures and the need for reform of the market infrastructure”, 2010, available at [http://www.icmagroup.org/assets/documents/Market-Practice/Regulatory-Policy/Repo-Markets/ICMA%20ERC%20European%20repo%20market%20white%20paper%20July%202010%20\(2\).pdf](http://www.icmagroup.org/assets/documents/Market-Practice/Regulatory-Policy/Repo-Markets/ICMA%20ERC%20European%20repo%20market%20white%20paper%20July%202010%20(2).pdf)

18 On 7 March 2012, the Commission adopted a proposal for a Regulation on improving securities settlement in the European Union and on central securities depositories (CSDs) and amending Directive 98/26/EC. The Regulation introduces an obligation of dematerialisation for most securities, harmonised settlement periods for most transactions in such securities, settlement discipline measures and common rules for central securities depositories (CSDs), see [http://ec.europa.eu/internal\\_market/financial-markets/central\\_securities\\_depositories/index\\_en.htm](http://ec.europa.eu/internal_market/financial-markets/central_securities_depositories/index_en.htm) CSDR was adopted by the EU Plenary on 15 April 2014 (see press release, available at [http://europa.eu/rapid/press-release\\_STATEMENT-14-130\\_en.htm](http://europa.eu/rapid/press-release_STATEMENT-14-130_en.htm)) and is expected to be published in the Official Journal during the third quarter of 2014.

**(ii) Work on triparty settlement interoperability and upgrade of the Bridge**

An important development in the European repo market is the growing integration of repo post-trade infrastructures, involving automated trading platforms, clearing through a CCP, triparty collateral management services and settlement at (I)CSD level. In the euro area, the increased use of CCPs for repo transactions in recent years is a noticeable development, whereby more than half of the repo transactions are cleared by CCPs<sup>19</sup>. Triparty collateral management services are provided by ‘triparty agents’<sup>20</sup>. These triparty agents provide a wide range of collateral management services that allow for more efficient settlement and more optimal management of collateral assets during the life of repo transactions. “Triparty settlement interoperability” (TSI) is an initiative that aims to improve the use of collateral in different collateral management and settlement locations in Europe. Triparty settlement interoperability aims to “unlock” liquidity and reduce costs/increase efficiencies. The implementation of robust and automated procedures in the context of triparty settlement interoperability arrangements could also reduce systemic risk. Enhancements to the link between the ICSDs (referred to as Bridge) are currently being explored by the ICSDs to better support settlement in CoBM, which include the extension of deadlines and improvements for same-day settlement (See report “Euro repo market: improvements for collateral and liquidity management”).

**(iii) ESF-ECSDA proposals to harmonise and standardise pre-settlement date matching processes throughout Europe (2006)<sup>21</sup>**

In 2006, a joint ESF (European Securities Forum) - ECSDA (European CSD Association) working group set out proposals to harmonise and standardise pre-settlement processes in European markets. The group proposed 17 standards across a range of headings: matching fields; principle of one matching instruction only; lifetime and timing of instructions; separation of matching from availability of cash and securities, hold/release mechanisms; electronic/automated matching including reporting/monitoring matching; tolerance amount for settlement. For the purposes of this report, further attention should be paid to the following areas:

- Lifetime and timing of instructions (standards 3 to 7): The report called for real-time continuous matching throughout the day up to and including settlement date, whereby matching takes place as early as possible.
- The separation of matching from availability of cash or securities, hold/release mechanisms (standards 8 and 9): The report recommended that matching of instructions should be separated from the availability of cash and securities while transactions should also be covered by hold/release mechanisms whereby the status of instructions can be changed.
- Electronic matching including reporting/monitoring matching (standards 10 to 16): The report proposed that the matching process should be fully automated and free of manual intervention at the (I)CSD. Matching status information should also be real-time and continuous throughout the business day and be automated.

19 For developments on the secured money market see ECB’s Euro Money Market Study, December 2012 and the ECB’s “Euro Money Market Survey”, November 2013.

20 Collateral management service providers include, but are not limited to, (I)CSDs, custodian banks or other entities offering such services. A distinction in triparty service providers can be made in view of the cash settlement, which could take place in CeBM (e.g. Euroclear ESES (Euroclear France, Euroclear Nederland, Euroclear Belgium), CBF, Euroclear UK&Ireland) or CoBM (e.g. Euroclear Bank, CBL, BNY Mellon CSD). In addition, the triparty agent could also be a commercial bank or custodian (e.g. JPMC, BNY Mellon).

21 [http://ec.europa.eu/internal\\_market/financial-markets/docs/cesame/giovannini/20061023-esf-ecsda-matching\\_en.pdf](http://ec.europa.eu/internal_market/financial-markets/docs/cesame/giovannini/20061023-esf-ecsda-matching_en.pdf)



#### (iv) Measures to reduce settlement fails and improve settlement discipline

One possible solution to improve settlement in CoBM (i.e. reduce settlement fails) is to look at improving the efficiency and discipline of the settlement regime, as has been previously reviewed by both the ECB and ECSDA. A trade is said to fail if on the intended settlement date either the seller does not deliver the securities in full and in due time or the buyer does not deliver funds in the appropriate form. In the context of securities settlement, the term fail is often employed to refer to the non-delivery of securities (in both free of payment (FOP) and delivery versus payment (DVP) cases), although with the adoption of DVP settlement mechanisms, fails can also derive from the non-settlement of the cash leg of the transaction. Failed transactions, if not resolved quickly, can have a knock-on effect on other transactions, potentially increasing the impact on the settlement process. This can in extreme circumstances seriously impair the whole settlement process.

An ECB report, *Settlement Fails – Report on securities settlement systems (SSS) measures to ensure timely settlement*, suggests that settlement fails may have negative impacts on collateral and securities lending markets.<sup>22</sup> This report suggested possible measures to prevent failed transactions which included:

- a high level of STP which would reduce manual intervention and accordingly reduce the mistakes in settlement instructions.
- use of a CCP, which, through the use of multilateral netting, can reduce the value of cash and securities to be settled to a more manageable net position.
- technical pre-settlement measures aimed at avoiding first-instance fails that can enable the correction of incorrect instructions.

The ECB report also outlined possible measures that could be taken to prevent and discourage fails, as the report notes that there are certain circumstances under which there may be insufficient incentives to avoid fails. Such measures to discourage fails could include increasing the cost of fails by imposing penalties on the guilty party; regular publication of data relating to chronic fails; and the suspension of participants in extreme cases of repeated fails.

In 2010, *ECSDA's report on settlement discipline in Europe*<sup>23</sup> recommended several measures that supported four main goals: 1) Early matching; 2) Early settlement on intended settlement date; 3) Prevention of fails; 4) Fast settlement of fails.

#### (v) CSD Regulation (including articles 6 and 7 covering measures to prevent and address settlement fails)

The Proposal for a Regulation on “improving securities settlement in the European Union and on central securities depositories” aims to create uniform rules on the organisation and conduct of CSDs to promote safe and smooth settlement.

Article 6 of the proposed CSDR stipulates that CSDs should use appropriate mechanisms to promote early settlement on the intended day of settlement. Following the adoption of the final CSDR rules, the European Securities Markets Authority (ESMA) will be tasked to draft regulatory technical standards, which will set out the requirements for measures to promote early settlement on the intended settlement date.<sup>24</sup>

<sup>22</sup> <http://www.ecb.europa.eu/pub/pdf/other/settlementfails042011en.pdf> - page 2.

<sup>23</sup> [http://www.ecb.europa.eu/paym/groups/pdf/ECSDA\\_settlement\\_discipline.pdf?53a5be0772acf32b50251f80b191003f](http://www.ecb.europa.eu/paym/groups/pdf/ECSDA_settlement_discipline.pdf?53a5be0772acf32b50251f80b191003f)

<sup>24</sup> ESMA has launched a full public consultation on the draft technical standards before they are to be submitted to the European Commission (EC). See <http://www.esma.europa.eu/content/Draft-Technical-Standards-Regulation-improving-securities-settlement-European-Union-and-cent>

Article 7 of the proposed CSDR specifies measures to address settlement fails and, amongst other things, requires CSDs to put in place a penalty mechanism which will serve as an effective deterrent for participants that cause settlement fails<sup>25</sup>. The CSDR prescribes that a CSD shall establish a system that monitors settlement fails, and shall provide regular reports to its competent authority or authorities as to the number and detail of settlement fails. Particularly noteworthy is a requirement that a buy-in be initiated within four days after the intended settlement date. It must be noted that before this can take effect, the settlement discipline measures of CSDR will require delegated acts and regulatory technical standards to be adopted.

#### 4 RECOMMENDATIONS FOR COBM SETTLEMENT PROCESSES

The following recommendations are derived from the combined assessment of all the above analysis, with a view to improving same-day DVP settlement related processes in CoBM. These recommendations should be understood as “guidelines” for the different industry actors in the multi-layered arrangements in CoBM settlement (that have been the subject of this analysis). In particular, the recommendations offer a set of elements for further alignment of CoBM-related processes that meet the aspirations to improve the efficiency of treasury management-related activities.

It is expected that the adoption of these recommendations will lead to efficiency gains in the processing chains of the euro repo/secured funding market by aligning CoBM processes to the services that will be offered in CeBM by T2S. It is acknowledged that operational or functional changes may be required by the participating actors (related to both internal systems and interactions between different market participants in processing chains). In any event, adherence to these recommendations will be left to market forces. The adoption should also not infringe on the commercial nature of the activities and services of the participants.

The focus of these recommendations should be considered in parallel with other market initiatives, and it should be noted that they are not intended to supersede any other industry agreements or regulations. In particular, the recommendations take into account the existing work related to (i) removal of operating differences in settlement systems (to be achieved through implementation of T2S, with a single platform, single business day schedule, etc.), (ii) alignment of settlement finality rules (also achieved with T2S); (iii) harmonisation of settlement discipline measures (driven by CSDR), and (iv) adoption of shortened settlement cycle (T+2, which will force the adoption of extensive automation).

With this report, the Joint Group would like to encourage further analysis and dialogue amongst all relevant market participants and stakeholders, to ensure that adequate consideration is given to the needs and constraints of each party, while at the same time creating a robust coordinated series of actions aimed at the definition and implementation of “best practices” for efficiency in post-trading settlement activities. Given the nature of the commercial services involved in the settlement processes analysed in this report, it is understood and expected that, as previously mentioned, adherence to these standards of best practices will be driven by market initiatives and by competitive “peer-pressure”.

<sup>25</sup> CSDR page 33. See <http://www.europarl.europa.eu/sides/getDoc.do?type=AMD&reference=A7-2013-0039&format=PDF&language=EN&secondRef=001-001>

#### 4.1 RECOMMENDATIONS FOR ENHANCEMENTS TO COBM SETTLEMENT PROCESSES

1. Instructing parties should ensure that all instructions to intermediaries are complete and correct, and transmitted as early as possible.
  - Instructing parties should examine possible improvements to the accuracy of their own internal systems, particularly regarding those systems that report on depot holdings (i.e. information on failed deliveries). This could decrease the number of deliveries that fail due to short positions, and should ensure greater efficiency in STP transactions.
  - Instructing parties should improve bilateral communication with their counterparties and have direct contact points with each in place (particularly in back office/settlement departments) so as to quickly resolve issues such as missing instructions. This is particularly important in the case of same-day trades instructed late in the day, where time is truly of the essence and any delays must be minimised to ensure settlement.
  - Instructing parties should ensure that instructions transmitted for settlement are delivered through industry-standard, secure electronic means and satisfy the formatting requirements of the CSD/Intermediary in order to cater for straight-through processing.
2. Under normal circumstances, intermediaries should submit their customers' instructions to the relevant SSS (or to the next intermediary in settlement processing chain) within 30 minutes of receipt, i.e. without undue delay, provided that the instructions are complete and correct and transmitted as early as possible using industry-standard, secure electronic means, and provided that the customer has the securities to be delivered and/or the cash is available.
3. Intermediaries that are direct CSD participants should ensure they have full capability for submission of customer instructions to the SSS up to the market cut-off (settlement deadline) of the relevant SSS. In other words, on the assumption that specific market practices and limitations in SSS functionalities do not create obstacles, intermediaries that are direct CSD participants should have the capability to:
  - process customer instructions until 3.30 p.m. CET for regular same-day value DVP settlement in euro (in line with CeBM settlement in T2S until 4 p.m.);
  - process customer instructions until 5.10 p.m. CET to support treasury adjustment operations in euro (in line with the corresponding bilaterally agreed treasury management (BATM) window for CeBM settlement in T2S until 5.40 p.m. CET).
4. Intermediaries should support a turnaround time<sup>26</sup> of no later than 60 minutes, provided that the instructions are complete and correct and transmitted as early as possible using industry-standard, secure electronic means, provided that the customer has the securities to be delivered and/or the cash is available, and provided that the (I)CSD provides its participants with status updates on securities settlement instructions on a real-time or quasi-real-time basis. Short turnaround times are important to integrated repo markets, particularly end-of-day treasury management transactions.

<sup>26</sup> Turnaround times indicate the interval between receipt of the customer's instruction and delivery of the settlement confirmation, or other relevant updates to the transaction status.

5. Appropriate systems should be established throughout the settlement processing chain to enable the monitoring of the status of instructions from the next party in the settlement processing chain. Intermediaries and (I)CSDs should aim to promptly inform their respective customers of potential settlement issues (and settlement fails) within 15 minutes of discovery.
  - Where possible, the processing of customer instructions should rely on automatic procedures. The automation of many of these functions should greatly enhance the efficiency of same-day settlement operations. Automation of settlement processes is highly important so as to eliminate manual procedures and build further on ESF-ECSDA proposals.
  - Persistent settlement failures should be investigated to identify the causes and contingency arrangements made to rectify such issues.

#### 4.2 RECOMMENDATIONS FOR (I)CSDS AND CSD LINKS

1. Links in CoBM should ideally be able to ensure real-time settlement or be able to support a full settlement cycle turn-around within an average of 30 minutes with a view to support the use of links for: (i) intraday re-use of collateral; and (ii) adjustment operations at the end of the day.
2. The settlement window for links in CoBM should operate until close to 4 p.m. CET for regular same-day value DVP settlement in euro (in line with CeBM links settlement in T2S).
3. DVP settlement should be available for links in CoBM until close to 5.40 p.m. CET to support treasury adjustment operations in euro (in line with the corresponding bilaterally agreed treasury management (BATM) window for CeBM settlement in T2S). The DVP settlement window for treasury adjustment operations in CoBM should be used exclusively for such operations, enforced by self-discipline of market participants.
4. Links in CoBM should support settlement interoperability for triparty repo products.

## ANNEX I ABRIDGED VERSION OF ERC SURVEY: A SURVEY OF INTERNAL CUT-OFF TIMES FOR SAME-DAY SECURITIES SETTLEMENT INSTRUCTIONS

### EXECUTIVE SUMMARY

A survey was conducted of the latest internal cut-off times for sending instructions for same-day settlement at ERC Operations Committee member firms. The objective of the survey was to detect systematic inefficiencies in securities settlement in commercial bank money (CoBM), recognising early cut-off times as one possible symptom of settlement inefficiency. The survey focused on fixed-income settlement in the four largest eurozone countries (France, Germany, Italy and Spain) and examined various settlement processing types and various alternative chains of settlement agents. The results of the survey represent a sample of the settlement conditions from 13 large players in the European repo market.

It must be noted that making direct comparisons between alternative settlement processing chains proved difficult, as firms tend to use one or another. Nevertheless, the survey revealed some evidence to suggest that there are currently various sources of delays and inefficiencies throughout the settlement processing chains.

There is somewhat firmer evidence that levels of internal efficiency vary widely between trading counterparties, reflecting in particular the trading counterparties' need to collect and collate data from several sources, the use of manual processes at several stages and the internal batch-processing of data. This suggests that there is scope for material improvements in operational efficiency within the trading counterparties themselves.

Another conclusion is that CoBM operations that include the ICSD Bridge can be subject to early deadlines, to which many factors contribute.

Given that the bulk of repo in Europe is traded electronically and/or cleared across central clearing counterparties (CCPs), these cut-offs are likely to be more important than the latest internal cut-offs, which regulate non-electronic and uncleared repo business.

### THE SURVEY

To ascertain whether there are systematic inefficiencies in securities settlement in CoBM, the Operations Committee of the European Repo Council (ERC) circulated a questionnaire to member firms (which is attached at Appendix I) requesting information regarding the latest internal cut-off times for sending instructions for same-day settlement of cash and repo trades for the following criteria:

- through three settlement processing types: final batch-processing; real-time or delivery versus payment (DVP); and free of payment (FOP);
- in four fixed income markets --- for government securities in France, Germany, Italy and Spain;
- via 11 possible settlement processing chains:

1. counterparty---CSD-counterparty (both parties are direct members of the CSD);
2. counterparty---CSD---ICSD---counterparty (one party is a direct member of the CSD; the other of the ICSD);
3. counterparty---ICSD---CSD---counterparty (one party is a direct member of the ICSD; the other of the CSD);
4. counterparty---ICSD---counterparty (both parties are direct members of the same ICSD);
5. counterparty---ICSD---ICSD---counterparty (the parties are direct members of different ICSDs, which are connected across “The Bridge”);
6. counterparty---custodian---CSD---counterparty (one party uses a custodian to connect to the CSD; the other is a direct member);
7. counterparty---custodian---CSD---same custodian---counterparty (both parties use the same custodian to connect to the same CSD);
8. counterparty---custodian---CSD---different custodian---counterparty (the parties use different custodians to connect to the same CSD);
9. counterparty---custodian---CSD---ICSD---counterparty (one party uses a custodian to connect to the CSD; the other is a direct member of an ICSD);
10. counterparty---custodian---CSD---ICSD---same custodian---counterparty (one party uses a custodian to connect to the CSD; the other uses the same custodian to connect to an ICSD);
11. counterparty---custodian---CSD---ICSD---different custodian---counterparty (one party uses a custodian to connect to the CSD; the other uses a different custodian to connect to an ICSD).

The questionnaire contained a number of qualitative questions to elicit reasons for earlier cut-off times.

In addition, the cut-off times for automatic repo trading systems (ATS) have been compiled and displayed in three additional diagrams in the Annex, with cut-offs added for their central clearing counterparties (CCPs). Given that the bulk of repo in Europe is traded electronically and/or cleared across CCPs, these cut-offs are likely to be more important than the latest internal cut-offs, which regulate non-electronic and uncleared repo business. If the trading day for the repo market is to be extended, it must include the ATS or electronic market. Indeed, an end-of-day liquidity management market could be electronic, if not also centrally-cleared.

## RESULTS

13 firms, representing significant market players, responded to the survey. The results are summarised in the attached set of diagrams. Each represents an alternative chain of settlement agents (as listed above). The red horizontal band in each row stretches between the earliest reported

internal cut-off time (on the left) and the latest (on the right). The vertical green lines represent CSD or ICSD cut-offs. The range of times is given in a column on the right and the number of responses in each row is given in a column on the left.

In order to place the internal cut-off times in context, the attached diagrams also show the various cut-off times of CSDs and ICSDs. In some cases, there appear to have been errors in the responses, with cut-off times for instructions reported as being later than the closure of the CSD (often because some replies gave GMT and not CET, as requested). Most of these mistakes have been rectified but they serve to demonstrate the considerable confusion within the market regarding cut-off times. This confusion may be compounded by inaccuracies in the cut-off times published by settlement agents and the complex range of alternative cut-off times for different types of settlement (mandatory v optional, internal v external instructions, DVP v FOP, member v third-party, delivery v receipt).

The survey also revealed a degree of flexibility in many cut-off times at both intermediaries/custodians.

A fundamental challenge to the survey is that trading counterparties tend to be either direct members of a CSD or use intermediaries/custodians. In order to definitively detect any delays due to intermediaries, it would be necessary to have more responses from trading counterparties that use both. Consequently, such delays have to be inferred by comparing the internal cut-off times of trading counterparties who are direct members of a CSD with the internal cut-off times of other trading counterparties who use intermediaries/custodians. This implicitly assumes that internal cut-offs do not materially differ between trading counterparties using the same settlement processing chain. This assumption is contestable, so any interpretations need to be treated as circumstantial.

It should be noted that, where there are mandatory and optional cut-off times, the analysis has used the latter, which means that the pressure of earlier cut-off times has sometimes been understated (by three hours in the case of the ICSDs).

#### INTERPRETATION OF SURVEY OF INTERNAL CUT-OFF TIMES

1. The CSD cut-off times are not dissimilar, being at or close to 4 p.m.. However, the Italian CSD appears to offer considerable flexibility, allowing late DVP settlement by bilateral agreement to 6 p.m. (the cut-off time for interbank payments on Target 2) and late FOP settlement to 6.15 p.m..
2. By comparing trading counterparties cut-off times in row 1 with rows 6-8 (i.e. CSD with v without custodians), and row 2 with 9-11 (i.e. CSD-ICSD links with v without custodians), it appears that custodians may add anything up to about three hours delay in DVP settlement. In France, there are delays of zero to one hour; in Italy, 45 minutes to almost four hours; in Spain, up to two hours; and in Germany, one to three hours. So internal cut-off times for settlement through custodians can be as early as 3 p.m. in France, 2 p.m. in Italy, 12 noon in Spain and 1 p.m. in Germany. However, the only direct comparison that could be made, for a trading counterparties settling real-time across a CSD in Spain, shows settlement involving a custodian having a cut-off time one hour earlier than direct settlement at the CSD.
3. CSD cut-off times for FOP settlement vary widely, from 6:15 p.m. in Italy and 6 p.m. in Germany to 5 p.m. in France and 4 p.m. in Spain.



4. By comparing trading counterparties cut-off times in rows 1 with 6-8, and 2 with 9-11 for FOP settlement, it appears that custodians may add anything up to over three hours delay. In France, there is no special delay; but, in Italy, it is up to about three hours; and it is up to three and a half hours in Germany. So internal cut-off times for settlement through custodians can be as early as 2.45 p.m. in Italy and 2.30 p.m. in Germany.
5. Comparing rows 9-11 with 6-8 (i.e. settlement through custodians with and without CSD-ICSD links) suggests that the involvement of a CSD-ICSD link does not introduce any special delay. This is important as settlement in Europe is characterised by a preference of many domestic fixed income investors to hold accounts at domestic CSD and the preference of dealers and global investors to concentrate accounts at ICSDs.
6. Greater confidence can be placed in the range of internal cut-off times at different trading counterparties shown on the charts (the width of the red band in each row). This ranges from an hour in the case of DVP settlement in France to four hours in Spain. The ranges in FOP settlement tend to be even wider, from under two hours in France to three and a half hours in Germany and over four hours in Spain.
7. A clear conclusion from the survey is that settlement across the Bridge, i.e. between the two ICSDs, requires additional operational steps which may lead to earlier deadlines. By comparing row 4 (i.e. settlement with an ICSD) and row 5 (settlement across the Bridge), one can see that, in DVP settlement, the Bridge has earlier cut-offs (i.e. advances internal cut-off times by between 30 minutes and three and a half hours), with the median towards the longer interval. In FOP settlement, the time differences are between zero and four hours.
8. There are differences that range from 15 minutes to over one hour between the mandatory settlement cut-off times of the ICSDs. Such sizeable inconsistencies between two essentially identical institutions suggest scope for improvements in performance by the ICSDs.

### ANSWERS TO QUALITATIVE QUESTIONS

The survey found that very few financial markets close before the trading counterparties' internal funding deadlines, which are dictated by the cut-off times of central bank payments systems. It would appear that repo desks do not have an earlier cut-off because of cash management needs. Instead, in order to maximise the trading day, trading counterparties tend to cease trading as close as possible to their internal deadlines (typically about 15 minutes in advance). In order to avoid accumulating large funding requirements at the end of the day, which would then have to be satisfied when market liquidity is low, treasury management operations, in effect, take place all day (and indeed may start the day before settlement in order to allow large projected balances to be pre-funded). Funding requirements are based on real-time projections of securities settlement and forecasts of intraday and end-of day cash positions made throughout the day. Forecasting and treasury operations can then be fine-tuned throughout the day.

Certain markets are reportedly easier to forecast than others, because of lower volumes (e.g. Spain compared with Italy). An important factor in treasury forecasts is the number and size of failed settlements. Estimates of expected fails have to be given as close as possible to the end of the trading day, but are dependent on reporting from (I)CSDs, directly or through intermediaries and custodian agents. Particular importance is attached to this requirement in certain markets, perhaps because of the penalties imposed on fails and the lack of auto-borrow facilities. Market practices

such as telephone pre-matching often reflect the practical requirements of the market, which may help explain earlier cut-offs in some of the markets examined.

In order to forecast accurately, treasury desks must be able to see cash balances and securities inventory throughout the day. Trading counterparties may have multiple securities and cash accounts for each of their main business lines (e.g. broker-dealer, custody, customer clearing), some held with agents, others in omnibus form, as well as core accounts for controlling flows. Systems and processes to collect and collate data from such diverse sources are also required.

Data from correspondent banks, custodians and (I)CSDs include net cash balances for real-time settlement in each market, confirmation that balances are final, fail notifications and reports on pre-funding already in place. Data collection is a possible source of delay as the data can be received via several different mediums, e.g. telephone, e-mail and via web portals. It has also been suggested that the volume of same-day business (overnight and intraday transactions) may encourage earlier internal cut-off times because of the scale of settlement volumes.

Some trading counterparties reported delays arising from the internal batch-processing of data (made worse by occasional systems disruption), as well as from the intervention of interface software like message handling systems that translate internal instructions into external formats such as that required by SWIFT. Routine delays may be in the order of 15-30 minutes, but there can be severe and extended disruptions.

Additionally, manual processes also contribute to delays. These include expert judgements involved in forecasting and the use of manual software applications. Manual intervention is also required in monitoring pre-matching, detecting short positions and liaising with counterparties, depot realignment, pursuing late or unmatched trades, deal repair and resending instructions, handling new issues, managing credit lines and securing approvals. However, survey responses suggest that delays as a result of manual process are usually not long (about 15 minutes), although it is not clear how much time they have allocated themselves in setting internal cut-off times.

Internal netting (operational netting of offsetting flows) and pair-offs (operational cancellation of offsetting trades) are used to enhance settlement efficiency, but these activities require many manual processes that most trading counterparties do not see contributing to delays. However, these functions require telephone and/or e-mail communication between counterparties that can potentially add delays.

From the survey responses, it appears that in most trading counterparties the repo and treasury desks operate independently, with the latter managing unsecured funding. However, they stress the close coordination between these functions and do not believe that integration would reduce the time between trading and end-of-day funding. Repo trading must cease earlier because CSD cut-off times are earlier than the cut-off times of central bank payment systems.

Anecdotal evidence suggests that, in instances whereby cut-off times are delayed, often as a result of enhancements to operational efficiency, internal cut-offs within banks have not always followed. One possibility is an element of inertia in operational procedures.

For settlement within a single ICSD (i.e. with another user of the same ICSD), settlement deadlines can be extended towards the ICSD cut-off of 6.30 p.m. CET, as settlement is simply an internal book-entry on the books of the ICSD and can be settled entirely in CoBM.

The same should be true of ICSD-ICSD settlement (where realignments between ICSD omnibus accounts at the relevant CSD can be made retrospectively) within the constraints imposed by local payment systems deadlines (as DVP between ICSDs require transfer of funds in the concerned currency).

## CONCLUSIONS

It could be argued that there is scope for improvement in the speed of settlement throughout the settlement processing chains and in most markets. However, considering the small number of respondents in this survey, further analysis may be required in order to better define findings and conclusions. For example, the lack of evidence for delays associated with custodians in France suggests that there may be infrastructure or other external constraints on custodians in other markets. In Italy and particularly Spain, the problem may be manual practices such as telephone pre-matching, which developed in response to market penalties for fails.

Additional background information and responses to the qualitative sections of the survey indicate that various initiatives currently in process have the potential to significantly improve the speed of settlement. For example, in Italy, new facilities such as hold-and-release and second-layer matching should help, but auto-borrow facilities at all CSDs would also assist. It is reasonable to suggest that settlement efficiency could be significantly accelerated by internal procedural improvements within banks themselves. Internal use of batch processing is a particular issue. Data collection also poses a challenge for some banks, but rectifying this is also dependent on the speed of reporting by correspondent banks, custodians and (I)CSDs.

There is strong evidence that the enhancements to the Bridge could yield very substantial benefits in terms of allowing later settlement.

**ERC REPORT APPENDIX I – CUT-OFF TIMES AS REPORTED BY ERC OPERATIONS COMMITTEE MEMBER FIRMS**

| ERC Report Appendix I – Cut-off times as reported by ERC Operations committee member firms |                       |               |              |            |            |           |            |           |               |              |
|--|-----------------------|---------------|--------------|------------|------------|-----------|------------|-----------|---------------|--------------|
|  |                       |               |              | EOC        | CBL        | CBF       | CBF        |           | Other Sources |              |
|  |                       |               |              |            |            | Domestic  | Customer   | Market    | Market        | Cross-border |
| France   | External Instructions | Real-Time     | AP           | 3.50 p.m.  | 3.45 p.m.  |           | 3.50 p.m.  | 4.00 p.m. |               |              |
|  |                       |               | FOP          | 3.50 p.m.  | 3.45 p.m.  |           | 3.50 p.m.  | 4.00 p.m. |               |              |
|  |                       |               | FOP ESES     | 4.50 p.m.  |            |           |            |           |               |              |
|  | Internal Instructions | Real-Time     | AP           | 3.30 p.m.  |            |           |            |           |               |              |
|  |                       |               | FOP          | 3.30 p.m.  |            |           |            |           |               |              |
|  |                       |               | AP Optional  | 6.30 p.m.  |            |           |            |           |               |              |
|  |                       |               | FOP Optional | 6.30 p.m.  |            |           |            |           |               |              |
| Cash   |                       |               |              |            |            |           | 4.15 p.m.  | 5.00 p.m. |               |              |
| Germany  | External Instructions | Batch Payment | AP           | 12.55 p.m. | 12.55 p.m. | 1.15 p.m. | 12.55 p.m. | 1.15 p.m. | 1.00 p.m.     |              |
|  |                       |               | FOP          | 5.30 p.m.  | 12.55 p.m. | 1.15 p.m. |            |           | 1.00 p.m.     |              |
|  |                       |               | AP           | 3.45 p.m.  | 3.40 p.m.  | 4.00 p.m. | 3.30 p.m.  | 4.00 p.m. | 3.45 p.m.     |              |
|  | Internal Instructions | Real-Time     | FOP          |            | 5.40 p.m.  | 6.00 p.m. | 5.40 p.m.  | 6.00 p.m. | 5.45 p.m.     |              |
|  |                       |               | AP           | 3.30 p.m.  |            |           |            |           |               |              |
|  |                       |               | FOP          | 3.30 p.m.  |            |           |            |           |               |              |
|  |                       |               | AP Optional  | 6.30 p.m.  |            |           |            |           |               |              |
|  |                       |               | FOP Optional | 6.30 p.m.  |            |           |            |           |               |              |
| Cash   |                       |               |              |            |            |           | 4.15 p.m.  | 5.00 p.m. | 3.00 p.m.     |              |
| Italy  | External Instructions | Real-Time     | AP           | 4.00 p.m.  | 4.15 p.m.  |           | 3.30 p.m.  | 4.00 p.m. | 6.00 p.m.     | 1.00 p.m.    |
|  |                       |               | FOP          | 4.20 p.m.  | 4.30 p.m.  |           | 5.30 p.m.  | 5.50 p.m. | 6.00 p.m.     | 1.00 p.m.    |
|  |                       |               | AP           | 3.30 p.m.  |            |           |            |           |               |              |
|  | Internal Instructions | Real-Time     | FOP          | 3.30 p.m.  |            |           |            |           |               |              |
|  |                       |               | AP           | 6.30 p.m.  |            |           |            |           |               |              |
|  |                       |               | AP Optional  | 6.30 p.m.  |            |           |            |           |               |              |
|  |                       |               | FOP Optional | 6.30 p.m.  |            |           |            |           |               |              |
| Cash   |                       |               |              |            |            |           | 4.30 p.m.  | 5.00 p.m. | 5.00 p.m.     |              |
| Spain  | External Instructions | Batch Payment |              |            | 2.50 p.m.  |           |            |           |               |              |
|  |                       |               | AP           | 3.25 p.m.  | 2.10 p.m.  |           | 3.00 p.m.  | 4.00 p.m. | 3.30 p.m.     |              |
|  |                       |               | FOP          | 3.25 p.m.  | 2.50 p.m.  |           |            |           | 3.30 p.m.     |              |
|  | Internal Instructions | Real-Time     | AP           | 3.30 p.m.  |            |           |            |           |               |              |
|  |                       |               | FOP          | 3.30 p.m.  |            |           |            |           |               |              |
|  |                       |               | AP           | 6.30 p.m.  |            |           |            |           |               |              |
|  |                       |               | AP Optional  | 6.30 p.m.  |            |           |            |           |               |              |
|  |                       |               | FOP Optional | 6.30 p.m.  |            |           |            |           |               |              |
| Cash   |                       |               |              |            |            |           | 4.15 p.m.  | 5.00 p.m. |               |              |
| Bridge   | Real-Time             |               | AP           | 1.00 p.m.  | 1.30 p.m.  |           |            |           |               |              |
|  |                       |               | FOP          | 1.00 p.m.  | 1.30 p.m.  |           |            |           |               |              |
|  |                       |               | AP           | 3.00 p.m.  | 3.00 p.m.  |           |            |           |               |              |
|  |                       |               | FOP          | 4.00 p.m.  | 4.00 p.m.  |           |            |           |               |              |

AP = Against payment  
 FOP = Free of payment  
 EOC = Euroclear  
 CBL = Clearstream Banking Luxembourg  
 CBF = Clearstream Banking Frankfurt

## ANNEX 2 ABRIDGED VERSION OF ERC SURVEY: THE IMPACT OF ATS AND CCP CUT-OFF TIMES ON SETTLEMENT IN COMMERCIAL BANK MONEY

The bulk of repos traded in European markets are negotiated and executed on automatic trading systems (ATS) and most of these (over 90%) are cleared across central clearing counterparties (CCP). The ERC survey therefore collected additional information on deadlines for sending instructions for same-day settlement for trades involving ATSs and CCPs, which were compared with the (I)CSD settlement deadlines. The earlier deadlines of ATSs and CCPs are particularly relevant for end-of-day liquidity management transactions, as these could be traded electronically on ATSs and centrally cleared on CCPs.

From the survey results, it is noticeable that the cut-off times for electronic trading involving CCPs are considerably earlier than (I)CSD cut-offs and electronic trading that is not centrally cleared by CCPs (often called “bilateral” trading). The survey covered the trading cut-offs for the three major repo ATS in Europe --- BrokerTec, Eurex Repo and MTS --- and included the cut-off times for the relevant CCPs and CSDs for the German, French, Italian and Spanish government bond overnight repo markets. The survey showed the following:

- the CCP cut-off times are considerably earlier than the CSD cut-off in the same market (i.e. CCP cut-off times are up to six hours earlier than the CSD cut-off in the same market).
- The ATS trading cut-off times are typically 30 minutes before the CCP cut-off (and could be up to 45 minutes before the CCP cut-off).
- The difference between the trading cut-off times and CCP cut-off times range from 1 hour to three and a quarter hours (e.g. the trading cut-off for BrokerTec is 10 a.m. CET for CCP-cleared German GC transactions, while it is 11 a.m. CET for bilaterally German GC transactions; in the Italian market, the cut-offs for BrokerTec are 11:45 for centrally-cleared GC and 3 p.m. for bilateral repos, making a gap of three and a quarter hours).
- Finally, there could be different trading cut-offs when involving different settlement locations. For example, in the case of Eurex Repo, there is a difference of five hours between the cut-offs for centrally-cleared repos that settle within an (I)CSD (3.30 p.m.) and those that settle across (I)CSDs (10.30 a.m.).

**Note:** As of 24 March 2014, clearing hours for Italian “same-day” repos have been extended by 45 minutes, whereby Italian “same-day” repos are now being accepted and registered until 12.45 p.m. CET by LCH.Clearnet SA. The new deadline applies for registered trades via the usual Trading & Matching Platforms or MTS Italy; however, these providers may operate an earlier deadline at their discretion.

## ANNEX 3 GLOSSARY

| Annex 3 Glossary                         |   |
|--|---|
| Allegation                               | An allegation is an instruction presented by a counterparty against an account for which there is no exact matching instruction.  |
| Automatic trading systems (ATS)          | Automated trading services provide an electronic interdealer platform for trading. Often, also post-trading services such as confirmation and matching are conducted automatically as part of the electronic platform.  |
| Treasury management                      | Treasury management refers to the management of a bank's holdings and assets, with the aim of maximising the bank's liquidity while mitigating exposure to risk. Treasury-related adjustment transactions refer to operations which are executed between financial institutions (inter-bank) towards the end of the day and on a same-day settlement basis (henceforth end-of-day treasury adjustments). The aim of such operations is to allow treasurers to adjust/square their cash positions following completion of regular settlement operations, including securities settlement operations. Rather than being confined to an end-of-day process, treasury management has increasingly become an all-day activity. Throughout the day, funding requirements are assessed based on real-time projections of securities settlement and cash positions. This in effect allows for fine tuning treasury operations as the settlement day progresses. |
| Same-day (intraday) settlement (SDS)     | Trades booked for same-day (intraday) settlement means that securities are booked/settled on trade day.   |
| Batch processing                         | A type of post-trading settlement comprises a process of groups of payments, transfer instruction, or other obligation together that follows one or more pre-specified time schedules and often accompanied by consequential settlement activities during the day.  |
| Bridge settlement                        | Securities transfers via the interoperable (I)CSD link between Euroclear Bank and Clearstream (Bridge) are settled via the exchanges of a number of matching and settlement files during the Overnight & Daylight Processing cycles. In ICSDs, the <i>mandatory</i> period is automatically made available to all ICSD participants. The choice to settle in the <i>optional</i> period is left to each trade counterparty and/or their custodians.   |
| Central bank money (CeBM)                | CeBM takes the form of deposits at a central bank and banknotes/coins.  |
| Commercial bank money (CoBM)             | CoBM is money issued in the form of deposit liabilities by commercial banks (i.e. the settlement asset is provided respectively by the central bank or commercial bank).  |
| Central securities depository (CSD)      | An entity that provides securities accounts, central safekeeping services, and asset services, which may include the administration of corporate actions and redemptions, and plays an important role in helping to ensure the integrity of securities issues (that is, ensure that securities are not accidentally or fraudulently created or destroyed or their details changed). A CSD can hold securities either in physical form (but immobilised) or in dematerialised form (that is, they exist only as electronic records). In many jurisdictions, a CSD also operates a securities settlement system.  |
| Collateral                               | An asset or third-party commitment that is used by a collateral provider to secure an obligation vis-à-vis a collateral taker.  |
| Custodian                                | An entity, usually a bank, that safekeeps and administers assets for its customers and that may provide various other services, including clearing and settlement, cash management, foreign exchange and securities lending, collateral management etc.   |
| Delivery versus payment (DvP)            | A securities settlement mechanism that links a securities transfer and a funds transfer in such a way as to ensure that delivery occurs if and only if the corresponding payment occurs. In this context, DvP could be achieved through a link between an SSS and a payment system. The SSS settles the securities leg of the transaction while the payment system settles the cash leg.  |
| Free of payment (FoP)                    | A transfer of securities without a corresponding transfer of funds.   |
| Real-time gross settlement (RTGS) system | A system that settles payments continuously in real time (that is, without deferral) and on a gross basis, typically on a payment-by-payment basis. A payment is accepted by the RTGS system once it successfully passes the system's validity and conditionality checks (such as that the sender has sufficient funds or credit available to send the payment) and is typically unconditional and irrevocable.   |
| Repurchase agreement (repo)              | A contract to sell and subsequently repurchase securities at a specific price either at a specific date or with an open maturity. The repo is, in effect, equivalent to a cash loan collateralised by securities, in which value of the securities collateral is marked to market, and resulting credit exposure is covered by the payment of cash or, the transfer of collateral from the over-collateralised party to under-collateralised party.   |

