

DLT-TF follow-up work on shareholder transparency

1. Introduction

In July 2017, the Advisory Group on Market Infrastructures for Securities and Collateral (AMI-SeCo) approved the forward looking plan for activities of the HSG DLT-TF and requested to concentrate efforts on: 1) assessing potential use cases for DLT application to securities post-trading in the areas of shareholder registration, corporate actions and taxation processing; 2) contributing to define standards to ensure an interoperable use of DLTs and their interaction with systems based on current mainstream technologies; and 3) designing governance frameworks that may facilitate the adoption of DLT across different institutions in a non-discriminatory basis, if such new tools should prove to be safe and to yield efficiency gains.

This note addresses the topic of shareholder transparency and outlines a high-level DLT use case proposal to possibly address open issues in current processes. The disclosure of shareholder information feeds the shareholder registration process, on which the AMI-SeCo requested follow up work and that is strongly linked to national specificities. The document is currently a living document describing the reflections and proposals from the DLT-TF to HSG members.

2. Current processes in the field of shareholder transparency

Shareholder transparency refers to the possibility for an issuer or its agent to identify shareholders and gather all information needed to involve them into the company decision making.

2.1. Information gathering process

When collecting information held by intermediaries involved in a holding chain solely in the domestic market of the issuer, an efficient and automated process works well [*view previously expressed in the T2S governance but not confirmed by DLT-TF members*] in most European markets.¹ Substantial problems emerge when issuers need information regarding the holdings and identities of their shareholders in other markets. The issuer or its agent needs to contact the Investor CSDs and/or foreign custodians to obtain a breakdown of holdings within their omnibus account.

When some of the entities listed are not the ultimate beneficial owners but rather intermediaries holding securities as nominees, the issuer or issuer's agent needs to send a similar request to all further layers down the holding chain (see Figure 1 Current process of information sharing for registration purposes **Error! Reference source not found.**, adapted from the report of the T2S Task Force on Shareholder Transparency (ST-TF)) until the intermediary (hereafter called "last intermediary") who deals directly with end investors at the end of every ramification of the chain is reached and can disclose end investors' information. As a

¹ See T2S Shareholder Transparency TF (2011) "[Market analysis of shareholder transparency regimes in Europe](#)".

result of various technical and legal difficulties, foreign intermediaries often choose not to disclose their information, or if they do, they reply with significant delay and errors that reduce the quality of data received by the issuer. The higher the volume of cross-border settlement, the more prominent this problem will become in the future.

Figure 1 Current process of information sharing for registration purposes

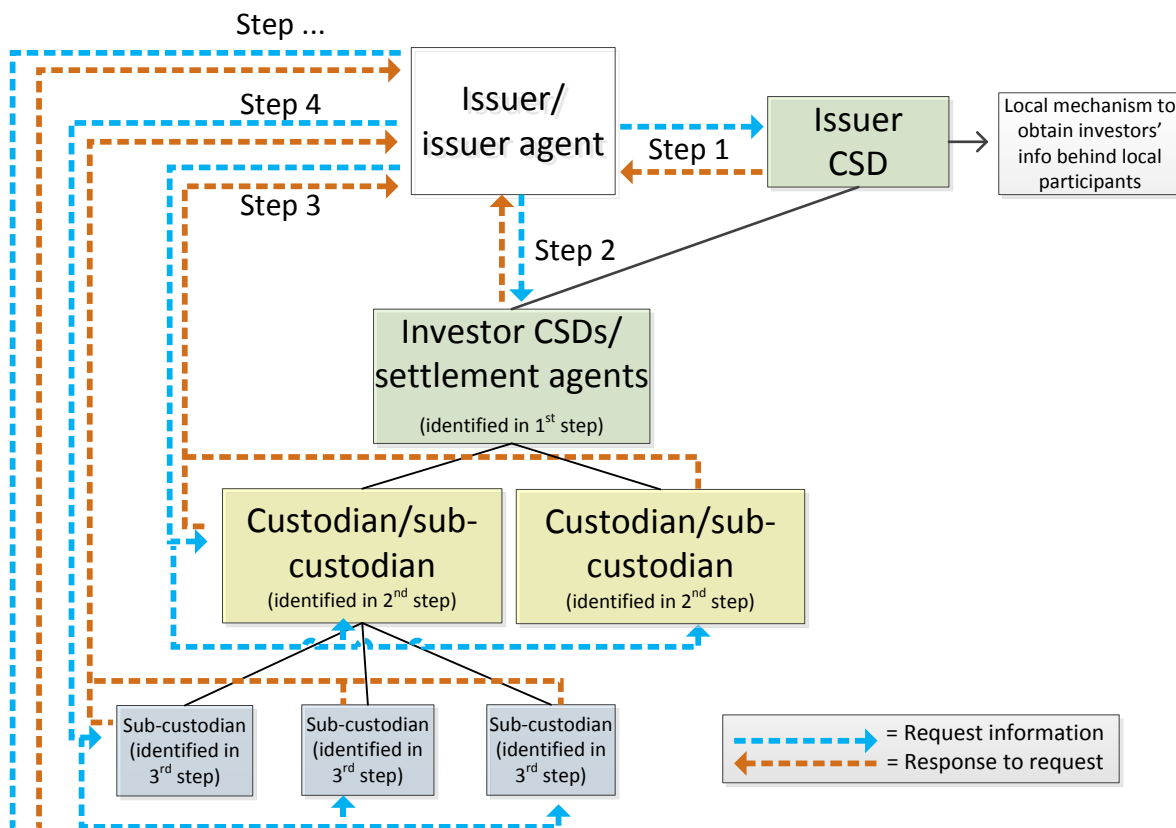

Difficulties of legal nature and solutions provided in the recast Shareholder Right Directive

From a legal perspective, the difficulties in the current process of shareholder identification start at the level of cross border disclosure requests (i.e., relating to shares issued under a foreign law, other than that which applies to the person holding the information). Under the currently applied regulatory framework and national laws, intermediaries have no clear guidance on how to reconcile issuer's rights for transparency regarding the identity of its shareholders with obligations to protect customers' data. Intermediaries are confronted with two important questions: (i) is the issuer entitled to request such information?; and (ii) is their customer entitled to prohibit its disclosure?

In order for issuers, intermediaries and investors to fulfil their tasks in a stable legal and cost environment across Member States, the 2017 recast of the Shareholder Rights Directive (SRD)² sets clear rights and responsibilities for the financial intermediaries that will be involved by issuers or their agents in the process of gathering data on their shareholders' identity. Intermediaries (including CSDs and third party service providers) have then to communicate to the issuer or its agent all relevant information regarding

² Directive (EU) 2017/828 of the European Parliament and of the Council of 17 May 2017 amending Directive 2007/36/EC as regards the encouragement of long-term shareholder engagement (Text with EEA relevance).

shareholders' identity.³ The same applies to intermediaries located outside the EU, in so far as they provide services to shareholders and other intermediaries with respect to shares of companies registered in a Member State or the shares of whom are admitted to trading on a regulated market operating within a Member State.

In holding chains, the SRD requires that information requests regarding shareholder identity must be transmitted between intermediaries without delay. The relevant information must then be shared directly by the intermediary who holds the requested information, either to the company or to a third party nominated by the company.⁴ An intermediary that discloses information regarding shareholders' identity is not considered to be in breach of any restriction on disclosure of information imposed by contract or by any legislative, regulatory or administrative provision.

In addition, the recast Directive addresses the protection of shareholders' personal data. Such personal data shall be processed free from national provisions on data confidentiality. Its purpose is to enable any company to identify its existing shareholders and communicate with them directly to facilitate the exercise of shareholders' rights and their engagement. Companies and intermediaries shall not store the personal data of shareholders transmitted for the purpose of shareholder identification for longer than 12 months after they become aware that the person concerned has ceased to be a shareholder.

Member States shall bring into force the laws, regulations and administrative provisions necessary to comply with the SRD by **10 June 2019**.

Difficulties of operational nature

Non-standardised formats and communication processes (e.g. usage of faxes or letters) make shareholder identification a labour-intensive business with high costs and suboptimal response rates. The process is rarely automated, especially cross-border, and there is no ISO standard to be used.⁵

The Commission will adopt implementing technical standards on shareholder identification by the 10th of September 2018, covering the format of information to be transmitted, the format of the request, including their security and interoperability, and the deadlines to be complied with. It will be necessary to consider technical standards before any further harmonisation initiative can be launched among market

³ The "information regarding shareholder identity" that has to be transmitted by intermediaries to issuers or third parties nominated by the issuers will include at least the following information: i) name and contact details (including full address and, where available, email address) of the shareholder, and, where it is a legal person, its registration number, or, if no registration number is available, its unique identifier, such as legal entity identifier; ii) the number of shares held; and iii) only insofar they are requested by the company, one or more of the following details: the categories or classes of shares held and the date from which shares have been held.

⁴ Member States are allowed to introduce a threshold not exceeding 0,5% for companies having a registered office on their territory, i.e. companies may only be allowed to request the identification of shareholders holding more than the above percentage of shares or voting rights.

⁵ Clearstream initiated in 2013 the set-up of ISO20022 messages for the reporting of balances of shares in investment funds. That was submitted for approval to the ISO in 2016:

https://www.iso20022.org/sites/default/files/documents/BJ/BJ079/ISO20022BJ_TransparencyHoldings_v2.pdf

participants and ahead of defining the details of any possible technical solution dealing with the new shareholder transparency regime.⁶

The SRD requires the European Commission to encourage by means of its implementing powers the use of modern technologies in communication between companies and their shareholders, including through intermediaries and, where appropriate, other market participants.

3. DLT-TF suggestions to address shareholder transparency related issues

3.1. Possible remaining challenges in the area of shareholder transparency

The entry into force of the recast SRD shall remove above mentioned legal obstacles that hinder the current transmission of shareholder information, including in cross-border holding chains. Implementing technical standards will cover the format and interoperability of the information request and disclosure processes. However, currently there are no solutions that can be considered ready to avoid fragmentation of the processes that financial intermediaries will follow to address requests received from a number of issuers using different channels. This is the main challenge tackled in DLT-TF work.

If not addressed by means of a market solution built around existing and on yet to be agreed standards, processes in the area of shareholder transparency may add substantial overhead to the back office of market participants. The SRD requires that intermediaries disclose publicly any applicable charges for the identification of shareholder identity and the exercise of shareholder rights, and differences between the charges levied on the domestic and cross-border exercise of right shall be permitted only when duly justified. Moreover, Member States may prohibit intermediaries from charging fees for identification of shareholders, transmission of information and facilitation of exercise of shareholder rights. That is likely to compress margins on the shareholder information disclosure process and may justify or even induce industry work to set up a utility service yielding network and scale economies, possibly by means of “modern technologies” as explicitly suggested in the SRD.

3.2. Main features of the use case under consideration by the DLT-TF

The DLT-TF has started reflections on a service that could address issues around shareholder transparency, on the type of functionalities that such service should include, and on whether any type of DLT could add value on top of a more traditional approach based on centralised database and reconciliation via peer-to-peer messaging.

The DLT-TF has taken stock of past work conducted on the topic by the T2S Taskforce on Shareholder Transparency (ST-TF), which in 2011 put forward four possible solutions for the workflow related with cross-border shareholder information.⁷ The ST-TF divided its proposals into “decentralised” solutions, operated by intermediaries among themselves, and “centralised” solutions, which used the T2S platform as a central reference for either account balances or messaging at the level of CSDs and CSD participants. The

⁶ It is worth noting that only six months (from the 10th of September 2018 to the 10th of June 2019) will be catered between the publication of implementing technical standards and the deadline for compliance of Member States with the SRD.

⁷ For details, please see the published [ST-TF report to the T2S Advisory group \(AG\)](#).

ST-TF concluded however that a decentralised approach would be needed to allow gathering information from layers of the holding chain other than T2S participants, and suggested that an ad-hoc messaging standard could improve its efficiency. The DLT-TF proposal builds on the ST-TF work and focuses on a decentralised approach outside the T2S platform.⁸

3.2.1. What the use case shall achieve: Pull vs. push approach

The use case put forward in the DLT-TF has been provisionally named Investor Data Directory (IDD). The IDD service shall provide a standardised way for any issuer (or its agent) to gather relevant information on its shareholders efficiently from their account providers.⁹ That will certainly require an industry-wide standardisation effort to ensure that a common data structure can be used across all ISINs by all intermediaries in the custody chain. This in turn requires governance, not only to set up the service but also to maintain and update it. The IDD would not provide any settlement service. It would only facilitate sharing of information after settlement, which happens by traditional means in the standard custody chain, is confirmed to all intermediaries involved and such intermediaries reflect the confirmed changes of holdings in the IDD database.

Two different ways to obtain the end investor's information have been considered: (1) information pulling method, by which the IDD provider, or any other entity delegated to maintain the register would contact the last intermediary holding any number of tokens in order to obtain (pull) information from the end investors; (2) the information pushing method, whereby the last intermediary who holds any number of tokens is responsible of sending (pushing) information by updating the IDD provider or any other entity delegated to receive such information.

Confidentiality of data and the rights of shareholders to amend the data or have it deleted (art. 3a(4-5) SRD) could be an issue if end investor's information were shared in the distributed ledger.¹⁰ The DLT-TF proposes storing end investor data in the proprietary system of authorised institutions (issuer and/or its agent), whereas the only information that is distributed and on which consistency is collectively enforced should be the list of intermediaries responsible for providing the information.

The pull approach would allow to achieve the most basic objective of an IDD service, which is to provide issuers or their agents with an automatically updated directory of who are the last intermediaries in every ramification of the custody chain – i.e. what intermediaries have relevant information on end investors, similarly to what is reported in the example in Figure 2. This would allow an issuer or its agent to pull such information by contacting directly the relevant intermediaries.¹¹

⁸ A centralised approach to track changes in the identity of the last intermediary responsible for any holding of shares, while ensuring participation of all intermediaries for information accuracy purposes, would require a central entity to be aware of all bilateral relationships among intermediaries in the custody chain. This could pose issues with regard to confidentiality and professional secrecy, as well as an operational overhead as the central entity would need to process all bilateral transfers that take place and connect them to ensure consistency.

⁹ The definition of shareholder depends on applicable national law. That matters especially in the case of funds, where it will be necessary to clarify the potential role of asset managers in an IDD network.

¹⁰ In theory, the IDD platform would be able to store information on end investors directly, however that is unnecessary and any decision on this is a matter of specification of the service requested by participating institutions.

¹¹ It shall be noted, with reference to figures 2 and 3, that the number attached to each share does not dispute their fungibility. Rather, it would represent the number of the corresponding record. The same information could be

Figure 2 Example of information visible to an issuer/agent via IDD (pull approach)

ISIN: XXXXXXXXXX (assuming 10 shares were issued)		
Share #	Information keeper	Contact of intermediary (BIC, Phone, Address, ...)
1	Intermediary "1"	XFLBUS..., 305-613-83..., Tree Plaza, Miami, FL , USA, ...
2	Intermediary "2"	XTSBDE..., 069-134-..., 4894 Berger Straße, FFM, DE, ...
3	Intermediary "2"	XTSBDE..., 069-134-..., 4894 Berger Straße, FFM, DE, ...
4	Intermediary "2"	XTSBDE..., 069-134-..., 4894 Berger Straße, FFM, DE, ...
5	Intermediary "2"	XTSBDE..., 069-134-..., 4894 Berger Straße, FFM, DE, ...
6	Intermediary "3"	XFLDORU..., 012-563-..., 24 Place Vendôme, Paris, FR, ...
7	Intermediary "3"	XFLDORU..., 012-563-..., 24 Place Vendôme, Paris, FR, ...
8	Intermediary "3"	XFLDORU..., 012-563-..., 24 Place Vendôme, Paris, FR, ...
9	Intermediary "4"	XXMKDU..., 067-237-..., 237 Via Nazionale, Roma, IT, ...
10	Intermediary "4"	XXMKDU..., 067-237-..., 237 Via Nazionale, Roma, IT, ...

The issuer or its agent would then have no need to contact every intermediary in the holding chain to finally get shareholder information from the last intermediary. Only the last step would be needed and the request/response could be channelled via messaging functionalities of the IDD service.

The push approach would represent a more sophisticated solution, where the IDD could be used to allocate tokens to the last intermediary in every branch of the custody chain. The last intermediaries could use the tokens as a proof of their entitlement to fulfil their obligation of updating shareholders' information (to push an update), in a separate database under the exclusive responsibility of the issuer, its agent, or any other authorised party who would ensure confidentiality of data. The envisaged outcome is represented in Figure 3.

Figure 3 Information visible to an issuer/agent in proprietary database with access control via IDD (push approach)

ISIN: XXXXXXXXXX (assuming 10 shares were issued)		
Share	Intermediary who updated record	Contact of shareholder (Name, Address, ...)
1	Intermediary 1	Jane Smith, 4894 Golden Street, Miami, FL , USA, ...
2	Intermediary 2	Erika Mustermann, 20 Sonnemannstraße, FFM, DE, ...
3	Intermediary 2	Erika Mustermann, 20 Sonnemannstraße, FFM, DE, ...

represented as a quantity entry specifying next to the name and contact of each information keeper the number of tokens under its responsibility.

4	Intermediary 2	Lieschen Müller, Löwenstraße 230, München, DE, ...
5	Intermediary 2	Lieschen Müller, Löwenstraße 230, München, DE, ...
6	Intermediary 3	Paul Martin, 179 Allée de Brienne, Toulouse, FR, ...
7	Intermediary 3	Paul Martin, 179 Allée de Brienne, Toulouse, FR, ...
8	Intermediary 3	Jean Dupont, 302 Rue Saint-Roch, Paris, FR, ...
9	Intermediary 4	Mario Rossi, via Luca Bianchi 128, Roma, IT, ...
10	Intermediary 4	Mario Rossi, via Luca Bianchi 128, Roma, IT, ...

With such solution, the issuer or its agent would not even need to bilaterally ask the last intermediary in each branch of the holding chain for shareholder information – the intermediary would be responsible for updating shareholder information either in real-time, or at pre-specified intervals, or upon public request from the issuer.

The HSG deemed the push approach as superior to the pull approach, since it allows to completely resolve the inefficiencies related with the current process of shareholder information gathering. The pull approach has its value in the possibility for issuers to identify what intermediaries hold information on the identity of their shareholders, but it does not resolve the issue of communication between such intermediaries and the issuer by means of standardised messaging across all ISINs involved.

3.2.2. How the IDD information would be updated

DLT-TF members see potential value in the use of shared bilateral ledgers to update the IDD. With that DLT solution, counterparties can update the subset of information that refers directly to their bilateral activity (possibly with other elected parties also accessing these records) and would ensure consistency of data held at different locations while protecting confidentiality.

The use of synchronised bilateral ledgers is considered for two reasons:

1) **It is necessary to involve all intermediaries along a holding chain** to ensure that the number of securities on which the last intermediary reports investor’s data is consistent with the holdings allocated to such intermediary. An alternative solution where the issuer agent would manage a centralised database, receiving information on investors at the last layer of the holding chain based on any information received, would be prone to mistakes or even potentially abuse by the parties providing such information. The participation of middle-layer intermediaries appears to be in line with the recast SRD, which envisages their involvement in the information flow related with shareholder identity.¹²

2) **The validation process shall ensure confidentiality of data.** That requires that only the relevant account provider is able to see and validate record updates involving holdings of its clients, one level below in the holding chain. A similar validation process shall happen at every step in the holding chain, where intermediaries at each level of a branch would validate record updates involving their clients’ accounts. Any intermediary or market infrastructure receiving matching update requests from two of its clients would

¹² See art. 3a(3) para.1 of the recast SRD

provide ultimate assurance that all bilateral ledgers affected are in sync and the IDD reflects the outcome of the settlement process.

- *High-level description*

Participants in an IDD network would be financial intermediaries and market infrastructures. Securities holdings would be represented by tokens held by IDD participants – for information sharing only and with no financial claim attached. Any change in securities holdings in the legally binding custody chain would be reflected in the IDD by means of transfers of tokens, which are governed by smart contracts initiated and validated by IDD participants only once settlement of a transaction has been confirmed to all parties involved in the custody chain.

IDD updates would be governed by smart contracts that are linked hierarchically to reflect relationships in the traditional and legally binding custody chain. In the description of an IDD solution we shall differentiate some times between “contracts” and “sub-contracts”, to specify when a smart contract (sub-contract) has to abide by the rules of the contract from which it has been derived. Besides the hierarchical aspects, these will all be just smart contracts requiring signatures from parties involved to update the ledger in which they are executed.

Looking at the right side of

Figure 4, a smart contract deployed by account provider “A” (e.g. CSD) to one of its account holders “B” (e.g. CSD participant) would allow the latter to transfer a number of tokens to another network participant “Z” (e.g. CSD participant) on behalf of its clients, which could be either end investors or intermediaries further down the traditional custody chain. If the transfer of tokens happens on behalf of intermediaries further down the custody chain, say on behalf of intermediary “C”, the transfer of tokens shall be governed by a sub-contract that B deployed to C in accordance with the contract it initially received from A. This step would take place only once, during the set-up phase of an IDD related to a specific issue.

The chain can of course be much longer, with C and Z deploying their own sub-contracts to their client intermediaries and so on, but let’s assume that C provides accounts to some end investors (“Alice” and “Bob”). In the graphical representation we also assume, for the sake of simplicity, that Z is a direct participant of A, who is then its account provider and deployer of smart contracts, and that Z provides accounts to some end investors (i.e “Charlie”).

As the settlement of a security transaction takes place and moves shares from a client of C to a client of Z, a transfer of tokens representing those shares in the IDD shall be initiated. Two approaches can be considered:

In a top-down approach, which is described in

- 1) Figure 4, the IDD participant A who received matching instructions in the custody chain (steps 1b and 2) shall confirm settlement (steps 3a-3b) and will initiate a smart contract updating the bilateral ledgers it holds with its clients accordingly.

Participant A would do so by initiating and signing a smart contract to update the two bilateral ledgers it holds with B and Z (step 3c). That means a transfer of tokens from B to Z would be ready to take place. Z can already apply its signature to the smart contract updating its bilateral ledger with A (step 4a), declaring itself as the candidate last intermediary in the chain for those tokens (still subject to confirmation from the B-branch). B is aware that the transfer involves its account relationship with C,

who is not an end investor. It then signs the sub-contract initiated by A, to update their bilateral ledger, and makes execution of such update conditional to successful updating of its bilateral ledger with C. When C signs the sub-contract in its quality of last intermediary in that branch of the custody chain, the transfer of tokens takes place and the IDD is updated.

Figure 4 Work-flow of the IDD (top-down approach)

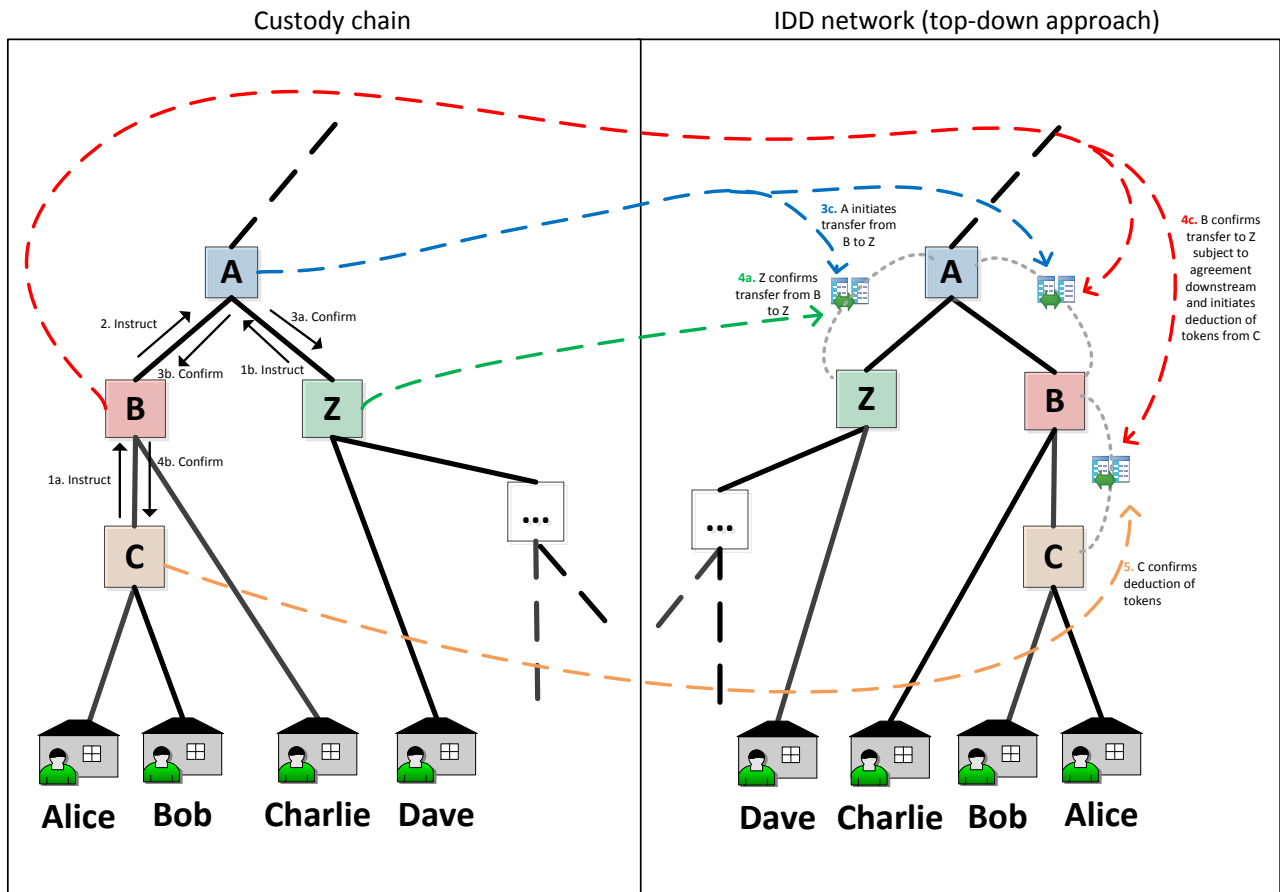

2) In a bottom-up approach (not depicted in Figure 4), the last intermediaries who initiated a securities transaction in the custody chain for their end investors (buyer and seller) would initiate the relative update in the IDD. The smart contracts called by the two last intermediaries C and Z are sub-contracts written in a way that they can only be executed if the respective contracts held by B and A are also signed. The two latter ones would then have to use their signatures to testify that the transfer of tokens corresponds to a confirmed settlement in the custody chain.

The contract used by B, however, is itself a sub-contract of the one used by A and it needs A to guarantee with its signature that the same instruction was settled and confirmed in the legally binding custody chain. The transfer of tokens takes place the moment A has approved the requests it received from B and Z, as no further contract up the chain is needed to achieve the matching of IDD instructions. The same would be true if the smart contract used by A was a sub-contract of another contract further up the holding chain: as long as an intermediary is involved that has visibility of both bilateral ledgers,

no additional signature is required.¹³ Like in the top-down approach, authorisation of the transfer of tokens via signature of a smart contract execution shall ideally be provided automatically after settlement of a transaction is confirmed in the traditional holding chain.

A potential solution to allow interfacing between the traditional holding chain and the IDD network is one where institutions in the traditional custody chain provide their signature of IDD smart contracts waiting for a signed sub-contract to instruct a movement of tokens that matches the content of their settlement confirmation – i.a. ISIN, quantities, and counterparties involved.

At the end of any of the two processes outlined above, the information available to the issuer or issuer agent is updated and shareholder information can be obtained by means of either the pull or push approach described in section 3.2.1.

- *Initial distribution of IDD tokens and smart contracts*

Each IDD token could represent shareholder transparency responsibilities over one share, or potentially over fractions of a share.¹⁴ Deployment of tokens and of smart contracts governing their transfers shall take place top-down.

The IDD service provider (e.g. an issuer agent) would customise the generic IDD smart contract agreed at the level of IDD governance to allow its use within a specific ISIN under its responsibility.¹⁵ The institution at the top-tier holding level, i.e. the issuer CSD, would deploy such smart contract to its direct participants in the first information layer and would allocate to each of them a number of tokens reflecting individual holdings. Each IDD participant in the first information layer would have the possibility to deploy the tokens it received from its own account provider to its account holders, together with sub-contracts of the IDD smart contract it received for that specific ISIN and that will allow further future transfers. Tokens and sub-contracts would be allocated based on the holding of each account holder in the traditional and legally binding holding chain. A similar process of deployment of tokens and of sub-contracts governing their transfers would allow distribution across intermediaries in the IDD network.

- *Special cases to be considered*

Netting: Records in the IDD distributed ledger are intended to reflect and spread information related to positions already settled in the proprietary database systems of intermediaries in the traditional holding chain. That means participants in the IDD do not need to process settlement instructions, e.g. with a view to implement netting algorithms, but they should only reflect changes in positions whose settlement is confirmed in the traditional system.

Frequency of IDD updates: The IDD could be updated either continuously or upon request/at end of day. Information about shareholders can either be *flow-based* (which means that information is constantly updated on a real time basis as result to transactions in a security) or *stock based* (information is updated at certain intervals in a ‘snapshot’ like manner, i.e. as a result of specific events such as Annual General Meeting, request from the issuer, etc.).

¹³ This case would only be valid for internalised settlement in the custody chain, and the process of updating the IDD would similarly require no intervention from intermediaries further up the custody chain.

¹⁴ If IDD tokens were to represent fractions of shares, a common denomination would be necessary – e.g., every token could represent one hundredth of a share. That may be connected to the concept of minimum settlement unit.

¹⁵ Provisions that are specific to a jurisdiction, such as the thresholds on minimum holdings that justify reporting of shareholders’ information to the issuer or to its agent, can be encoded in the smart contract used in each ISIN-specific IDD ledger under the national law of the issuer.

A flow-based approach would allow the IDD service provider for any ISIN to automatically receive updated information on last intermediaries/end investors at any time and would allow solving any operational issues ahead of key events such as general meetings or record dates. Any changes in the holding chain (including intraday) would be immediately reflected upon settlement. However, the processing/cost overhead¹⁶ is yet to be determined and flow-based approach could be heavy to implement as this replicates any movement in the custody chain. That would not be an issue if IDD users were able to use application programming interfaces (APIs) to translate their settlement confirmation messages into equivalent instructions executing/signing IDD smart contracts (a solution still to be assessed).

If an easy interfacing is not feasible, a stock-based solution where updates take place only upon justified request (semi-manual process) or at the end of each business day (automated process dealing with ledger updates in batches) appear more feasible and may still suffice to make shareholders' information available with a frequency that allow substantial efficiency gains in the area of shareholder transparency for the purpose of updating shareholder registers. Optimal timing in this case is still an open question and shall be based on the experience of intermediaries with regard to their reconciliation processes as well as on legal analysis. As intermediaries in the custody chain carry out regular reconciliation processes at different intervals, the timing of these processes and the consequent change in the information fed into the IDD service would likely guide any decision in this respect. From a legal perspective, the update of IDD would be intrinsically linked to the moment when the acquisition of the shareholder status becomes effective. That depends on rules governing the transfer of ownership (trade date/settlement date) which may vary across jurisdictions. Such heterogeneity shall be reflected in the overall functioning of the IDD service as well as in the coding of its ISIN-specific smart contracts.

Broken branches: If an intermediary dealing with a certain security does not participate in the IDD network, the information stored in the distributed ledger can only be updated up to the level of its account provider, whereas its own account holders are cut-off (concerning the share held with it). This is also mentioned as a main challenge in the next subsection. Participation in the IDD network cannot be compulsory, and cost-efficiency as well as competition among intermediaries would be the driver of possible adoption. An intermediary that does not participate would impede access of its account holders to the IDD service and would force them to respond to issuers' request by means of alternative and possibly more costly solutions.

Additional possible uses of the IDD service

An IDD service would not be meant to replace existing systems used for settlement of securities transactions but is intended to be complementary to them. It could eventually be applied to a broader range of further challenges, if appropriately designed, without foreseeable need for significant further investment.

Initially the new system should have a lean but expandable scope. Beyond the topic of identification and disclosure of shareholder information, the platform could be leveraged to allow proxy voting, communication on portfolio transfer information, (e.g. tax information in countries such as Italy and France, or beneficiary information for MiFIR), processing of cash flows at source with no need for tax

¹⁶ It shall be noted that an IDD participant only processes updates that have taken place at the level of its accounts and does not intercept the rest of the network traffic.

reclaim processing and reporting, and enhancement of existing manual processes in the corporate actions space.

One important feature that this solution could add to the current custody chain is to provide issuers with information on the duration of positions held by individual shareholders, allowing issuers to grant additional rights to shareholders that have held their positions for a long time. The classic example is double voting rights, as well as some other bonus rights (France, in particular, has such types of bonus rights).

3.3. Potential challenges and points of concern

Interfacing between the traditional systems of financial intermediaries and an IDD needs to be assessed to ensure both that updates in the IDD ledger happen automatically upon confirmation of settlement (or at any specified cut-off time) and that any possible malfunctioning of the service can be identified by means of regular reconciliation mechanisms. An IDD platform should be designed in compliance with the SRD and its technical standards, paying attention to the work of and possibly engaging in a dialogue with the European Commission that is empowered to adopt them by 10 September 2018.

A major point of concern, already mentioned above, is the possibility that intermediaries could opt for different ways to take part in the information flow, and the IDD would not scale. Like any other network utility service, an IDD would only be effective if a sufficiently high number of institutions use it and form a critical mass able to attract other institutions that may not be directly involved in its design. That is particularly important at the top levels of the custody chain. As long as the issuer or its agent cannot oblige intermediaries to participate in a specific IDD platform, its usage will depend on subjective cost-analysis by each entity and that may limit the advantages brought by a common IDD. One or more service providers could allow intermediaries who, possibly due to the volume of their activity, do not have an interest in setting up the IT infrastructure needed to participate directly in the IDD service, to participate indirectly by delegating the translation of their internal confirmation messages into instructions that are compatible with the functioning of the IDD.¹⁷

Lastly, a third issue to be addressed is related to the IDD governance. It should provide standards to ensure resilience of the service and simplify synchronization between the IDD network and the standard settlement accounts, as well as to define the type of smart contracts to be used. These topics shall be tackled in other work streams of the current DLT-TF activity, in line with the follow-up work requested by the AMI-SeCo.

AMI-SeCo members are invited to:

- **Provide feedback on the use case study; and**
- **Provide guidance on possible further work ahead of the next AMI-SeCo meeting.**

¹⁷ See e.g. SWIFT, where only 4,000 BICs out of 11,000 are self-managed.

Investor Data Directory (IDD) that could be used for assets settled in T2S and potentially beyond

A service for the efficient and confidential sharing of investors' data (e.g. to update shareholders' registers)

In a nutshell: ledger would be updated upon confirmation of settlement in the custody chain to provide information on shareholders' and/or on the "last intermediary" responsible to provide such information.

Note: Main legal reference for platform design is the Shareholders Rights Directive (SRD). National applicable law for use in registration process should that of the issuer.

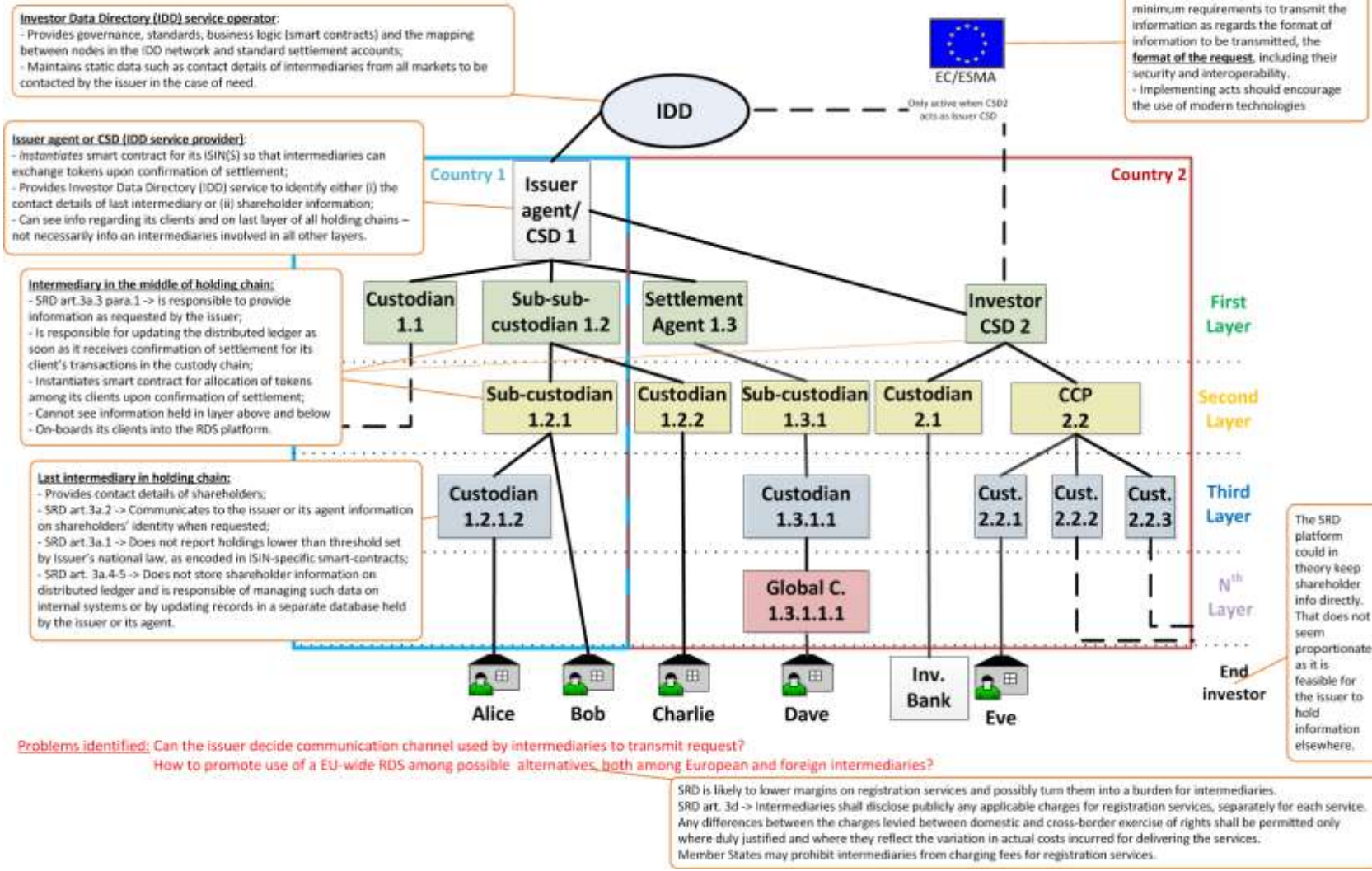

Annex 2: Proposals made by the ST-TF to address issues related to shareholder registration process and transparency

I) CSD disclosure service

The first model is building on the existing link between an Issuer CSD and an Investor CSD, either of which could be the main actor in the process (as described in Figure 5 and Figure 5, respectively). The issuer or Issuer Agent would make a Shareholder Disclosure Requests (SD request) via Issuer CSD, to receive from any of its Investor CSDs the breakdown of account holders in their omnibus accounts (first layer information). Based on this breakdown a second request would then be sent to obtain information on the breakdown of account holders further down the holding chain (second layer information) either a) by the Issuer CSD to participants of the Investor CSDs or b) by the Investor CSDs to their own participants. The Issuer CSD or, in case (b), the investor CSD, would then need to follow the same procedure to collect the subsequent layers of information all the way down to the end investors.

Figure 5 CSD disclosure service via Issuer CSD

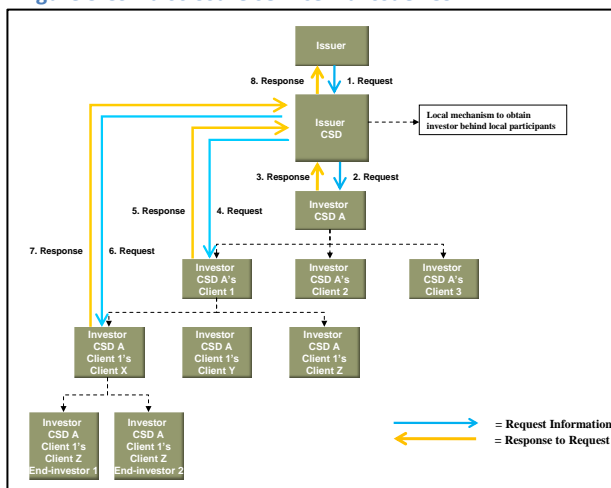
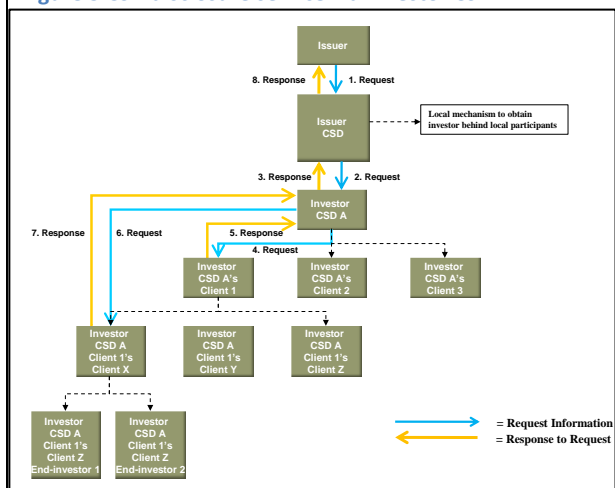

Figure 5 CSD disclosure service via Investor CSD



II) Issuer agent disclosure service

In the second model (described in Figure 7 below) the Issuer Agent substitutes the role of the Issuer CSD in making the initial SD request to the Investor CSD, as well as to the Issuer CSD, to obtain first layer information. All the characteristics applying to the first model are practically identical for the second one.

Figure 8 T2S data extraction model

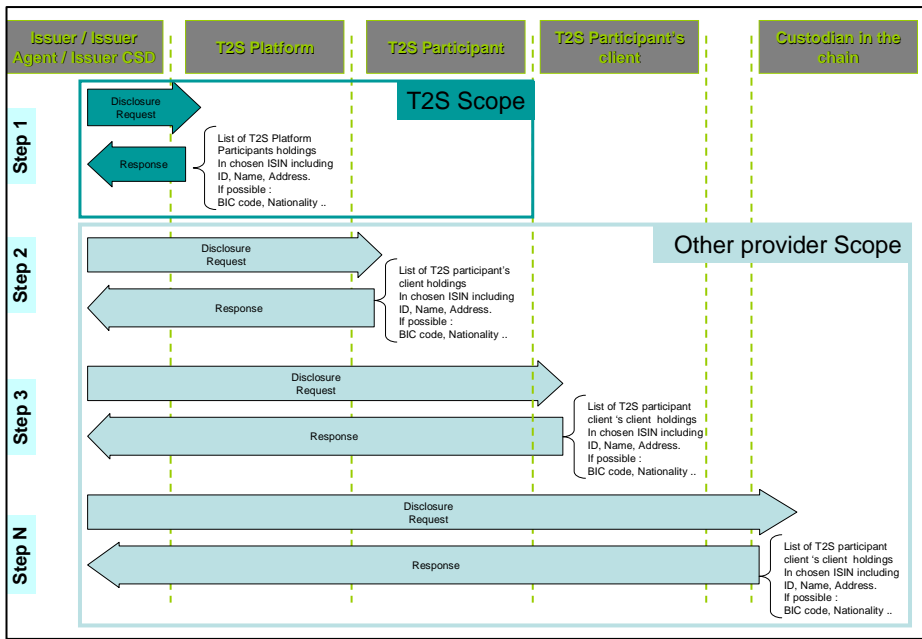

IV) T2S messaging hub

Finally, in the fourth model (Figure 9) the T2S SDRP can obtain all Issuer CSD and Investor CSDs account level information directly from the platform. However, T2S messages of the type “Corporate Action announcement” are used to obtain such information up to the level of clients of T2S participants. To contact and obtain registration information from entities at lower layers of the holding chain, the accounts of which are not available via parties connected to the T2S platform, the SDRP would still need to use one of the two models previously described.

Figure 9 T2S messaging hub model

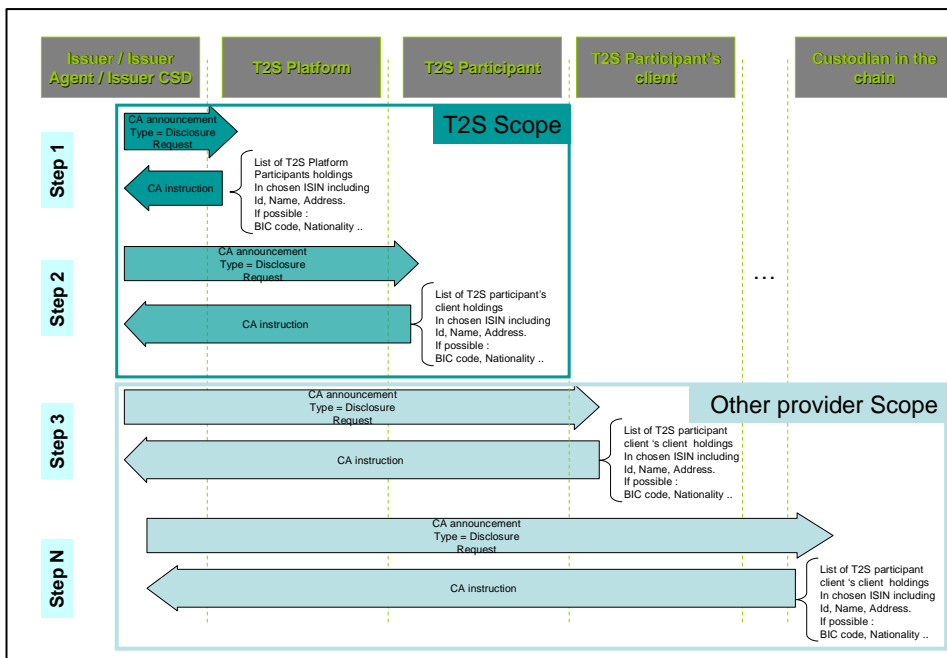

V Messaging standard

Regardless of the models used for shareholder disclosure, the ST-TF found that market participants need an ISO disclosure message standard that could apply both to local as to cross-border disclosure requests. At the first layer information (i.e., CSD account holder) it is expected that the issuers be able to request all accounts and their balances for a specific ISIN at the end of day, or all accounts that have changed during the day for a specific ISIN at the end of the day. At subsequent layers of information, the SDRP sends a request (message 1) to the Investor CSD/Custodian who would then return details of holdings of their respective clients (message 2). After processing the information, the SDRP may choose to request the same breakdown from any of the holders at the subsequent layers and the process continues in the same way until the issuer confirms she received all the required information. A proposal was made to ISO by ST-TF members¹⁸. DLT-TF members are welcome to share any information on the status of this request and on its elements that could be leveraged in DLT-TF work.

¹⁸ https://www.iso20022.org/sites/default/files/documents/BJ/BJ079/ISO20022BJ_TransparencyHoldings_v2.pdf